



Peak

Cemafruid

Peak Measurement Methods

Peak.cemafruid.com



6^d March 2026

Cemafroid SAS
5 avenue des Prés
94260 Fresnes
contact@cemafroid.fr
peak.cemafroid.fr

All rights reserved. No part of this document may be reproduced and/or published by means of printing, photocopying, microfilm or by any other means without prior written permission from Cemafroid.

This version of the PEAK measurement methods is the official version based on previous Peak measurement noise methods established in March 2026. In the event of discrepancies between this English version and other versions, the latest one shall prevail.

© 2026 Cemafroid



Foreword

This document is the Peak measurement methods to be used for the testing of equipment intended to be Peak certified.

This document is a technical standard established by Cemafruid based on consulting stakeholders within the PEAK technical committee.

Laboratories responsible for conducting type testing of equipment candidates for Peak certification must be recognized by the certification body (Cemafruid) and implement this standard.

Additional requirements apply for the acceptance of tests: see the document “Peak certification scheme.”

The legislation on noise, in the main cities in Europe, relates to emergence, the sound level on the facade. Even though every effort has been made for a Peak certified product, it is possible that the legal noise standards are not met in certain loading/unloading situations. The relation between vehicle sound emission and sound emergence at receiver depends on many factors, falling within the three categories: sound sources, sound transmission/propagation and receiver point. In other words, the sound from the vehicle or the activity, the venue consisting of the surrounding buildings and walls, parks or open lands, etc., and finally the absorption and bending of the propagating sound in the air – the ambient temperature, humidity and air pressure constitute the media of the propagating sound wave.



Foreword

This standard presents the Peak measurement methods published by Cemafroid.

Peak aims to certify products and vehicles that meet the noise standard set by Cemafroid and have been tested according to the present Peak measurement methods.

PEAK certified products contribute to reducing noise emissions during loading and unloading operations and thus enable evening/night delivery.

These measurement methods are intended for everyone involved in producing and marketing new equipment and materials used in loading and unloading goods in the retail trade.

The legislation on noise, in the main cities in Europe, relates to emergence, the sound level on the facade. Even though every effort has been made for a Peak certified product, it is possible that the legal noise standards are not met in certain loading/unloading situations. The relation between vehicle sound emission and sound emergence at receiver depends on many factors, falling within the three categories: sound sources, sound transmission/propagation and receiver point. In other words, the sound from the vehicle or the activity, the venue consisting of the surrounding buildings and walls, parks or open lands, etc, and finally the absorption and bending of the propagating sound in the air – the ambient temperature, humidity and air pressure constitute the media of the propagating sound wave.

A measurement and report in accordance with this standard enables participants of Peak to have their component type-approval certified.

All products relevant for Peak that are present in the certified vehicle shall be part of a Peak or QuietTRUCK type approval. The products comply, in that case, with the Peak values measured according to the Peak measurement methods.



Preamble

To establish the Peak certification scheme, Cemafruid has drawn up two additional documents:

- this document, which presents the test protocols to be applied by Peak-approved laboratories in order to draw up test reports
- a document entitled “Peak certification scheme,” which presents the certification procedures, the requirements applicable to products, the procedures for laboratory approval, and the model type conformity certificates and equipment conformity labels.



Summary

This document describes the methods of measurement that are suitable for determining the peak noise levels of various sound sources during loading and unloading. Peak in general and these methods of measurement are specifically intended for the certification of products during loading and unloading at retailers or shops. They are not intended for other means like the reduction of normal road-traffic noise. The methods of measurement provide peak sound levels of single sources under controlled conditions at 7.5 meters from the source.

The methods of measurement are set up to yield both representative and reproducible results, which approach the practical conditions as closely as possible. The methods are set up in such a way that noise-reducing measures are clearly expressed in the measurement results.

The Peak certification values can be used to obtain an indication of whether the product in question will meet the required sound emission limits in most practical situations and provide the local authority with a tool for assessing the potential of a Peak certified product or a QuietTRUCK vehicle in relation to the environmental goals. Furthermore, the methods of measurement are used to compare the peak noise emissions of products with each other.

The methods include:

- Driving noise for trucks, noise caused by cabin doors
- Doors, hatches, hinged and roller doors and sliding partition, steps and strip curtains of cargo body and/or load compartments.
- Tail lift, body floors and walls of commercial vehicles
- Shopping trolleys, goods carts, rollies, dollies and hand pallet trucks
- Forklift trucks and mobile forklift trucks
- Transport refrigeration system



Table of contents

Introduction	11
1.1 Objective, background and scope of the methods of measurement	11
1.2 Directionality.....	11
1.3 PEAK mode.....	12
1.4 Definitions.....	13
2. Technical committee in charge of the test protocol	14
2.1 Role of the Peak technical committee.....	14
2.2 Rule for the adoption of changes to the reference framework (PEAK protocol)	14
3. Measuring equipment, general measuring conditions and procedure	14
3.1 Measuring equipment.....	14
3.2 Measuring conditions.....	15
3.3 Measurements	17
4. Method of measurement for driveline noise of trucks and alarm systems.....	20
4.1 Measuring course, measuring conditions.....	20
4.2 Accelerating	21
4.3 Compressed air noise	23
4.3.1 Alternative method for blowing off or decompressing the service/foot brake.....	23
4.4 Reversing alarm system and blind spot warning system.....	24
4.4.1 Reversing alarm system:	24
4.4.2 Blind spot warning system:.....	25
4.5 Pass-by sound.....	26
5. Method of measurement for opening and closing doors of loading areas and cabins and air curtains for cargo bodies and sliding partitions, steps and strip curtains.....	28
5.1 Vehicle loading area doors, hatches and hinged doors and air curtains of cargo bodies.....	28
5.1.1 Measuring arrangement.....	28
5.1.2 Method of measurement.....	29
5.2 Cabin doors.....	29
5.2.1 Minimum Door closing speed.....	29
5.2.2 Measurement of door closing sound	30
5.3 Roller doors and sliding panels.....	31

5.4	Sliding partition wall.....	32
5.4.1	Moving	32
5.4.2	Unlocking and locking.....	33
5.5	Steps.....	33
5.6	Strip curtain	34
5.6.1	Sliding	34
5.6.2	Moving in direction of travel.....	35
5.6.3	Collision with the strips	35
6.	Methods of measurement for the tail lift and walls of vehicles and lashing devices..	37
6.1	Measuring arrangement	37
6.2	Tail lift.....	38
6.2.1	Opening and closing.....	39
6.2.2	Roll-off stop.....	39
6.3	Rolling noise	40
6.3.1	Rolling over the tail lift.....	40
6.3.2	Rolling over the floor of the cargo body	41
6.3.3	Rolling over transitions (e.g. from tail lift to cargo body floor)	41
6.4	Noise of collision with walls of the cargo body	41
6.4.1	Wall	41
6.4.2	Front end	43
6.5	Load fastening system.....	44
6.5.1	Straps	44
6.5.2	Clamping blocks placing.....	45
6.5.3	Clamping blocks moving in hight.....	45
7.	Method of measurement for shopping trolleys and pallet trucks	47
7.1	Rolling noise	47
8.	Method of measurement for roll containers, rollies and dollies.....	49
8.1	Rolling noise	49
8.1.1	Loaded	49
8.1.2	Rolling nested roll containers	49
8.1.3	Rolling empty roll containers that cannot be nested	49
8.1.4	Rolling stacked rollies and dollies.....	49
8.2	Colliding/nesting roll containers	49

8.3	Placing and removing additional loading shelves.....	50
8.4	Stacking rollies and dollies.....	50
9.	Method of measurement for forklift trucks and mobile forklift trucks.....	51
9.1	Driving.....	51
9.1.1	Measurement procedure.....	51
9.2	Evaluation of lifting.....	52
9.3	Evaluation of connecting mobile forklift truck.....	52
10.	Method of measurement for transport refrigeration	53
10.1	Types of transport refrigeration	53
10.1.1	Refrigeration system with integrated combustion engine	53
10.1.2	Refrigeration system without separate combustion engine.....	53
10.1.3	Refrigeration system based on an “open” gas system.....	53
10.1.4	Refrigeration system with eutectic mass	53
10.2	Measuring arrangements.....	54
10.2.1	Measuring points for refrigeration unit at front end.....	54
10.2.2	Measuring points for refrigeration unit underneath cargo body.....	54
10.2.3	Additional measuring point for unit powered by trucks engine.....	55
10.2.4	Additional measuring points for driving system underneath cargo body	55
10.3	Measurement procedures	56
10.3.1	Evaluation of refrigeration system with integrated combustion engine (see 10.1.1 Refrigeration system with integrated combustion engine)	56
10.3.2	Evaluation of refrigeration system without separate combustion engine (see 10.1.2.1 Refrigeration system without separate combustion engine)	57
10.3.3	Evaluation of refrigeration system without separate combustion engine (see 10.1.2.2 Refrigeration system without separate combustion engine, with a compressor directly connected to the vehicle’s engine)	58
10.3.4	Evaluation of refrigeration system without separate combustion engine (see 10.1.2.3 Refrigeration system without separate combustion engine, with additional support by a (quickly exchangeable) powerpack).....	58
10.3.5	Evaluation of refrigeration system with external combustion engine (see 10.1.2.4 Systems with the original integrated diesel engine installed externally).....	59
10.3.6	Evaluation of electrically powered refrigeration system with a connection to the public mains and refrigeration system based on an “open” gas system with a connection to the public mains	60
10.3.7	Evaluation of electrically powered refrigeration system with a connection to the vehicle’s battery and refrigeration system based on an “open” gas system with a connection to the vehicle’s battery.....	60

10.4	Refrigeration system with “PEAK mode”	61
11.	Reporting	62
11.1	General information	62
11.2	Product details	64
11.2.1	Vehicle doors, hatches, hinged and roller doors	64
11.2.2	Air curtain	65
11.2.3	Roller door	66
11.2.4	Sliding panel 1 Sl	67
11.2.5	Sliding partition	68
11.2.6	Steps	69
11.2.7	Strip curtain	69
11.2.8	Tail lift	70
11.2.9	Floor	71
11.2.10	Wall	72
11.2.11	Load fastening system	74
11.2.12	Refrigeration unit	74
11.2.13	QuietTruck	77
11.2.14	Reversing alarm system and blind spot warning	81
11.2.15	Rollies and dollies	82
11.2.16	Roll container	82
11.2.17	Pallet truck	83
12.	References	84

Introduction

This standard describes methods of measurement that are suitable for determining the peak noise levels of relevant sources of noise during loading and unloading.

Measuring methods determine peak noise levels for single sources under controlled conditions at 7.5 meters from the source. Measurement methods are set up to yield both representative and reproducible results, which approach practical conditions as closely as possible. Furthermore, the methods of measurement are set up in such a way that the noise-reducing measures are clearly expressed in the measurement results.

Technology develops at lightning speed; Peak is no exception to this. This protocol incorporates relevant innovations.

1.1 Objective, background and scope of the methods of measurement

Most regulations in major cities on peak noise during loading and unloading apply to the peak noise level at any outside wall of a building nearby for the activity in practical conditions.

The stated levels of the Peak certified product can be used to obtain an indication of whether the product in question will meet the legal limit values in most practical situations. It may be, however, that the combination of the Peak certified product and the acoustic environment, the method of operation and the state of maintenance of the product will affect the sound emission level in a real situation.

Furthermore, the methods of measurement can be used to compare the peak noise emissions of products with each other.

The methods of measurement are intended to evaluate partial sources in their practical conditions, where there is interaction with other components. To receive reproducible measurements, some measurement methods are not in line with practical conditions. An example of this is the simulation of a roller container in a collision with the wall, whereas the roller container does not make the collision to the wall during the measurement but a steel ball.

The methods are not suitable for determining sound power.

1.2 Directionality

Many sound sources have directional sound radiation, which means that sound levels vary depending on the direction from which sound radiates. As sound can be observed in all possible directions in terms of the sound source in inner-city situations (both around and above the noise source), the measured level should be the maximum sound level from all possible radiation directions. This type of measurement may require disproportionate measurement efforts in practice,



especially in the case of highly variable noises. For practical reasons, the aim therefore was to prescribe as few measuring points as possible. The radiation directions that are expected to be most critical, however, were considered. For some sound sources, such as moving vehicles, it is difficult to measure in all radiation directions. Here it was decided, in accordance with international regulations, to measure the left and right of the traveling path of the vehicle only. Conversely, the method of measurement shall not result in sound-limiting measures being designed so that the maximum effects are achieved only in the direction of the measuring points indicated in this report. An example of less-than-optimal design (for inner-city use) is transport refrigeration systems installed at the front end of a cargo body. The insulating enclosure is often designed in such a way that an effect is achieved horizontally, but little effect upwards. The top of the enclosure is usually left open.

1.3 PEAK mode

For various products/machines present on a vehicle, the speed of functioning may affect the sound level produced by the part. Examples of this are the revolution of the (electric) motor of a refrigeration or a truck's engine. If the part has two speeds and the product/machine is tested at the low-speed setting, this is called "PEAK ou PIEK mode".

If a product or machine has a "PEAK mode" it should activate automatically and should not function dependent on the actions of the driver. "PEAK mode" shall ensure that the part/machine meets the Peak sound requirements within 300 meters from the loading/unloading location.

The basic principle of a "PEAK mode" is that it is driver-independent and that, outside of the PEAK-specified time frames and outside of the so-called PEAK locations, the machine can be set to maximum power (for example software) with technical tools. In other words, "PEAK mode" is the default operating setting of the machine. In case of a defect in the technical tool or other faults relating to the functioning of "PEAK mode", the part/machine shall operate in "PEAK mode". The functioning of "PEAK mode" shall be guaranteed. The functioning of "PEAK mode" shall also be demonstrated and described in the report.

The above-mentioned demands do not apply to Driveline and Acoustic Safety systems sound of trucks (in accordance with Chapter 4). The "PEAK mode" for QuietTRUCK may be operated manually and does not need to be independent driver. Vehicles which require driver intervention to switch on the "PEAK mode" should switch this function on as soon as they enter a zone of 300 meters surrounding the loading/unloading location.

In the case the "PEAK mode" is automatically activated – geofencing/time of the day – it is allowed to activate the "PEAK mode" by software during the tests if necessary.



1.4 Definitions

- n_{rated} : The rated engine speed means the declared engine speed in min^{-1} (RPM) at which the engine develops its rated maximum net power pursuant to UN/ECE Regulation No 85 or, where the rated maximum net power is reached at several engine speeds, the highest one of those speeds is taken.
- n_{max} : The highest engine speed can be achieved without engine load.
- $n_{\text{max reduced}}$: The maximum idling speed if a reduced “PEAK mode” in engine management has been activated.
- P_n : Rated maximum net power, the engine power available for propulsion expressed in kW and measured by the method pursuant to UN/ECE Regulation No 85 and stated in the Vehicle Type Approval.
- m_{test} : The total mass of the vehicle that is being tested is the actual weight during the measurement including the driver, measurement equipment, in case needed the added mass in accordance with paragraph 4.1 etc.
- “PEAK mode”: A deliberately changed operating condition in a product with the goal of temporarily reducing sound production.
- Vehicle: a motor vehicle with or without a (semi) trailer or a (semi) trailer
- Truck: a motor vehicle designed and constructed primarily for the carriage of goods of categories N2 or N3 as defined in the EU Regulation 2018/858
 - N2: motor vehicles with a maximum mass exceeding 3,5 tons but not exceeding 12 tons
 - N3: motor vehicles with a maximum mass exceeding 12 tons
- Trailer: means any non-self-propelled vehicle on wheels designed and constructed to be towed by a motor vehicle.
- Semi-trailer: a towed vehicle in which the axle, or axles are positioned behind the center of gravity of the vehicle.
- Target object: the object being tested, either a product as specified in chapters 5 to 10 or a vehicle (including added mass) and test equipment. In case the product is mounted to a vehicle, the vehicle is part of the target object. In case the product is part of a vehicle cargo body the vehicle cargo body shall be complete/ready built for the purpose of the test.
- Participant: company affiliated with Cemafroid.
- $L_{pA, \text{max}}$: maximum measured A-weighted Sound Pressure Level with integration Time set to “FAST”.



2. Technical committee in charge of the test protocol

2.1 Role of the Peak technical committee

The role of the PEAK Technical Committee is to ensure the technical development of the test protocol and certification rules for equipment covered by the current protocol. The technical committee of the pic protocol is not a certification committee within the meaning of ISO 17065. It brings together all the experts in the field to establish the rules relating to testing to ensure that the equipment complies with the noise levels defined by the PEAK protocol. The technical committee is also in charge of establishing the rules for the recognition of third-party evaluations already carried out on the equipment as well as the technical requirements relating to the recognition of test reports. The composition of the committee may be modified by CEMAFROID to include representatives or additional expertise necessary for the development or evolution of the protocol.

2.2 Rule for the adoption of changes to the reference framework (PEAK protocol)

The Committee shall endeavor to adopt the technical developments of the PEAK measurement methods Protocol by consensus. If this is not possible, the opinions of the members may be obtained in writing. Cemafruid adopts the changes in the light of the comments of the committee participants.

For all other questions (tariffs, evaluation procedures), decisions are taken by a simple majority of the members present. In the event of a tie vote, the president has the casting vote.

3. Measuring equipment, general measuring conditions and procedure

The requirements made on the equipment, acoustic environment, meteorological conditions and background level mostly reflect those included in UN/ECE regulation R51 Annex 3 [3]. The following deviations and additions apply:

3.1 Measuring equipment

The required measurement equipment shall comply with the following specifications to perform PEAK measurements:



- Sound level meter, type 1 (in conformity with “IEC 61672-1:2013: Sound Level Meters”, equipped with an A filter, “Fast” adjustable integration time and read-out option set to “Max. Hold” or an equivalent data acquisition system (to be proven using certificates)
- Windshield for microphone
- Acoustic source type 1 (in accordance with IEC 60942:2017, Sound calibrator) to calibrate the sound level meter
- Speedometer, accuracy +/- 1 km/h
- Revolution counter, accuracy +/- 3%

The sound level meter and the acoustic source shall be calibrated by a certified institution at least once every two years. The necessary certificates for the measuring equipment used shall be submitted to Cemafroid upon request.

3.2 Measuring conditions

During measuring, the background noise level ($L_{pA, max}$) should be at least 10 dB(A) lower than the noise level produced by the source/activity being assessed. Ideally, the background noise level in the area should be lower than 45 dB(A). The background noise level is the maximum noise level $L_{pA, max}$ resulting from external sources during the execution of a PEAK sound measurement. The background noise level shall be determined by measuring the maximum noise level $L_{pA, max}$ resulting from external sources, for a period of 10 seconds. The background noise level shall be determined at the start of the measurement. It is recommended that the test site provides stable background noise for at least 1 minute, to ensure sound recording is not contaminated. This background noise level shall be recorded. No corrections are to be carried out due to eventual contributions from background noise.

The current wind speed (at the measurement height) may not exceed 5.0 m/s during the sound measurement interval.

Sound measurements should be carried out when it is dry. The air temperature should be between 5.0 and 40.0°C.

There should not be any reflecting outer walls or objects within a radius of 25m from the object to be measured or the microphone(s). There should not be any objects or people between the target object and the microphone.

Ideally, measurements should be executed in a testing area and on a surface which meets the requirements in ISO 10844:2021 and certified. In case of a stationary test the target, object shall be positioned such that the surface under the microphone and under the target object and between the target object and microphone(s), as well as within a radius of at least 1 meter surrounding that area shall be smooth and ‘acoustically’ hard.



However, to ensure that the methods of measurement remain accessible to smaller manufacturers, acoustically comparable testing areas may be used, like a car park, as long as they meet the following qualifications:

- This testing area is large enough to accommodate the prescribed actions and/or movements the target object needs to perform as well as being large enough to accommodate microphone(s) at the prescribed distance.
 - The surface under the microphone(s) and under the target object and between the (moving) target objects and microphone(s), as well as within a radius of at least 1 meter surrounding that area shall be smooth and 'acoustically' hard. In figure 3.1 and 3.2 examples are given of the minimum 'acoustically' hard surface when the test location does not have an ISO 10844:2021 certification. In the figures about the measurement setup in the chapters 4-10 the minimum 'acoustically' hard surface is also indicated.
 - 'Acoustically hard' is understood to mean an absorption coefficient of $\leq 10\%$ in the frequency range of 315 up to and including 1600 Hz.
 - Surfaces that meet these requirements: a flat closed surface consisting of dense concrete, dense clinkers or dense asphalt concrete are considered sufficient.
 - Other surfaces are considered insufficient. Surfaces that do not meet these requirements are in any case
 - (loos or pressed) sand, soil or gravel,
 - (bare or planted) ground, open or semi dense road surfaces, including porous asphalt, surfaces with vegetation.

Surfaces that are not fully composed of acoustically hard materials are also not sufficient as are cracked and broken concrete surfaces.

The minimum 'acoustically' hard surface shall be clean and dry and free of any snow, ice, leaves, vegetation, sand or noise scattering and/or noise absorbing substances.

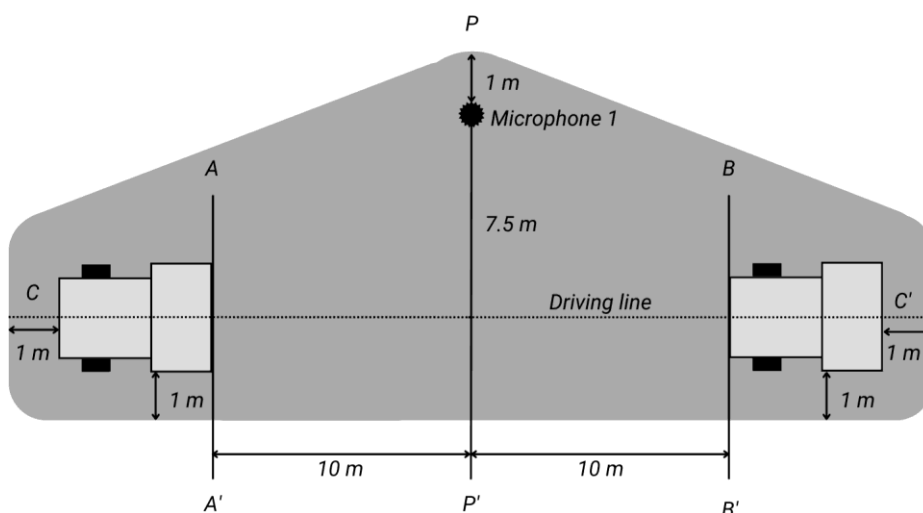

Figure 3.1: Minimum dimensions for the acoustically hard surface (e.g. to determine the pass by noise of vehicles in accordance with paragraph 4.5)

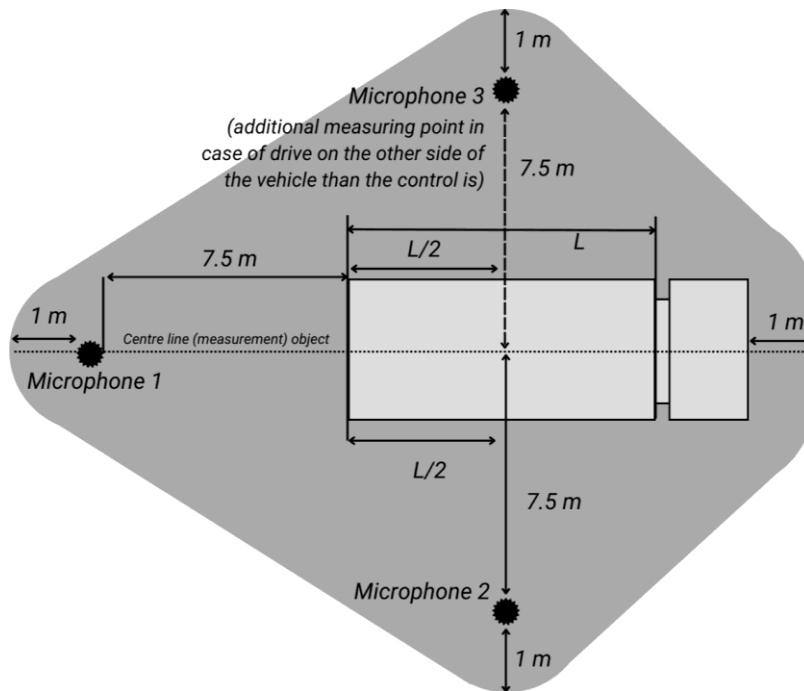

Figure 3.2: Minimum dimensions for the acoustically hard surface (e.g. to determine the sound of tail lift in accordance with paragraph 6.1). The drive system of the tail lift is located on the other side of the vehicle than the control.

Deviations can be made from the measurement conditions described. However, this is only permitted if it leads to higher noise levels. Some examples are:

- Obstacles behind the target object or sound level meter if these obstacles are nearer to these items than prescribed
- Higher levels of background noise than permitted
- Measurements are carried out indoors instead of outdoors
- A wet surface or a surface with a rougher finish

Deviations which may result in lower noise levels are not permitted. Examples include:

- Obstacles located between the target object and the sound level meter
- Absorbent surfaces like pervious asphalt or gravel
- Surfaces covered in snow, leaves etc.

All deviations from the prescribed measurement conditions shall be accurately recorded in the report in writing and with sufficient images.

3.3 Measurements



For stationary tests, the microphone is aimed at the measured object, parallel to the ground. For moving objects, the microphone is also directed perpendicular to the direction of movement. The standard measuring distance for moving test objects is 7.5m from the driving line, and for stationary set-ups 7.5m from the axis of the object to be measured, on the side of the noise source. A stationary set-up at 7.5m from the edge of the target object is required for 'some' measurements. The standard microphone height is between 1.2m ± 0.02m above the road surface.

The target object to be measured must be placed horizontally.

All measurements (measurement distances, courses, etc.) which are listed in the test protocol are subject to a standard tolerance of 1% unless otherwise stated.

All target speeds are subject to a standard tolerance of 10% with at least 1 km/h allowed, unless noted otherwise. For measurements where no target speed is stated in the measurement method, such as doors of loading area (see paragraph 5.1) and steps (see paragraph 5.5), the measurement shall be carried out at a speed that corresponds to normal practical use.

Measurements outside the tolerance area or measurements with unexpected, non-representative noise peaks shall be discounted.

Complete working cycles are always measured at least 3 times.

In general, measurements will be taken in an unloaded condition, unless the paragraphs in question demand a loaded condition. Readings of non-representative interrupted or erroneous measurements shall be removed. If only one microphone (sound level meter) is available, the prescribed number of actions will have to be carried out for each measuring point.

A reading of the A-weighted maximum sound level ($L_{A,max}$) will be recorded during the prescribed working cycle with the settings – 'Fast' and 'Max hold' activated – using a sound level meter or an equivalent setting on a measurement system.

The following paragraphs indicate how the sound level is specified for each type of source.

In some cases, the highest value of multiple readings will be determined and arithmetically rounded to the nearest integer number in dB(A), see table 3.1

1 st reading	2 nd reading	3 rd reading	4 th reading	Highest value
86.3	87.6	86.8	84.5	88

Table 3.1: Example of highest value reading rounded to the nearest integer number

In other test set-ups, an energetic average sound level will be determined for a number of $L_{A,max}$ values. The energetic average of a series of n measured values $L_1, L_2, L_3, \dots, L_n$ is defined in accordance with:



$$L_{gem} = 10 \lg((10^{L_1/10} + 10^{L_2/10} + \dots + 10^{L_n/10})/n)$$

For energetic averaging over multiple measurements, only the average value is arithmetically rounded to the nearest integer number in dB(A), see table 3.2.

1 st reading	2 nd reading	3 rd reading	4 th reading	Energetic average value
86.3	87.4	86.8	84.5	86

Table 3.2: Example of energetic averaging with rounding to the nearest integer number

The number of averages varies depending on the type of measurement. The number of averages may be increased, which may result in a more stable average value. The recorded results are read off and presented with one decimal place. The mathematical results are presented with one decimal place.

The evaluation result is then presented in the whole dB. Rounding to the nearest integer is done arithmetically. This means that, if the number to be rounded ends in 5 after the decimal point, it is rounded to the higher nearest integer. For example, 40.5 is rounded to 41.



4. Method of measurement for driveline noise of trucks and alarm systems

4.1 Measuring course, measuring conditions

The measuring course shall be part of a straight section of road. A microphone is placed halfway along the measuring course at $7.5\text{m} \pm 0.075\text{m}$ in line CC' with the microphone (see figure 4.1). The sound measurements can be done with a single microphone (sound level meter), in which case the measuring course shall be driven from right to left and from left to right to measure both sides of the vehicle. One direction is deemed sufficient if two microphones (sound level meters) are available. However, one microphone can be moved back and forth depending on local situations or the participants' preferences.

At least three measurements are taken on both sides of the truck. The following measuring conditions apply to the truck:

- The truck to be measured shall be in normal, ready-to-use condition.
 - If the truck is fitted with fan(s) having an automatic actuating mechanism, this system shall not be interfered with during the measurements.
 - Due to repeated noise measurements at low speed, the vehicle might get warmer than normal, and engine cooling fans might engage automatically. In such cases, it might be necessary to cool down the vehicle between repeated noise measurements, by driving some time at a higher speed.
 - Cabin climate control systems or air conditioning systems should be switched off during noise measurements.
- Trucks which have multiple modes (sport, eco, winter, off-road, etc.) should activate the standard mode used for driving on public roads.
- If the truck is equipped with a "PEAK mode" function, the tests can be performed with "PEAK mode" activated. This is on condition that the driver has access to the "PEAK mode" switch inside the cabin or if "PEAK mode" is automatically activated by the vehicle itself.
- Load during sound measurements:
 - During the sound measurements, the test mass m_{test} shall be $50 [\text{kg}/\text{kW}] \times P_n [\text{kW}]$ where P_n equals the truck's maximum power output in an unlimited condition. When the weight of the truck with driver and measurement equipment does not fulfill to m_{test} it is required to add added load to achieve the desired test mass. However, the sum of the added load and the rear axle load in an unladen condition is limited to 75% of the technically permissible maximum laden mass allowed for the rear axle. The measured test mass shall be reported in the test report.



- The tolerance for the prescribed test mass is +/- 5%.
- The prescribed added load shall be placed as close as possible on top of the rear axle of the vehicle but not behind the rear axle. The test mass of a truck with more than two axles in the same product family shall be the same as for a two-axle vehicle. The added load may not affect the sound emission of the powertrain resulting from the vehicle, i.e. it may not be equipped with noise absorbent and/or noise blocking surfaces. These constructions for carrying the added load and the added load may not contribute to the noise produced in any significant way, e.g. the truck should not contain any loose, rattling items.
- The presence or use of a vehicle body, articulated element or a (semi)trailer for transporting the load is not permitted unless this type of construction is standard for the truck and is covered by the “Representative vehicle scenario” definition which has been described in paragraph 2.3.2 Representative vehicle.

Given the low speed during testing, tyre noise falls outside the scope of this test. For a low and reproducible sound level during the test of traction tyres, winter tyres or other tyres with a coarse tyre profile shall be excluded. Please note that the tyres shall meet the legal requirements for use on public roads.

4.2 Accelerating

The following procedure shall be completed, for the measurement setup see figure 4.1:

The 1st series of measurements (for all vehicles): accelerating and changing gears if necessary

- The length of the measuring course is 20 m (10 m before and 10 m after the microphone).
- The loaded truck at the beginning of the measurement is standing still and is located at the start of the course (before line AA') and is ready to accelerate. This means for example (if applicable):
 - With an an idling engine.
 - PEAK mode has been activated.
 - The brakes are on if necessary.
 - Trucks with a manual gearbox should be in the appropriate gear for driving off on a flat road considering the test mass of the vehicle, in normal urban driving. The engine is disengaged.
The used starting gear shall be reported in the test report.
 - Trucks with automatic transmission, adaptive transmissions, and transmissions with variable gear ratio tested with non-locked gear ratios should be placed in the standard mode for driving forward and automatic shifting (D/Drive).
- The truck should then accelerate as quickly as possible, at full throttle, from a



stationary position.

- Acceleration will continue until one of the following situations occurs:
 - A speed of 20 km/h is reached.
 - The rear of the vehicle reaches the end of the course at line BB'.

At that moment, the accelerator is released, the measurement is stopped, and the noise levels are recorded.

- On the measuring course, gears may need to be shifted.
 - Trucks with an automatic gearbox will shift automatically, and the moment to shift gear, if relevant, may be supported by a PEAK mode.
 - Trucks with manual transmission require the driver to change gears as quickly as possible to the next higher gear, as soon as:
 - the RPM $A \times n_{\text{rated}}$, is reached. Factor A equals
 - $0,68 < A < 0,76$ for category N2 trucks
 - $0,83 < A < 0,91$ for category N3 trucks
 - the RPM $n_{\text{max reduced}}$ is achieved (if the test is being carried out in PEAK mode). After shifting gear, the driver again goes full throttle as quickly as possible to accelerate as much as possible. This procedure for accelerating and shifting gears may need to be repeated several times until the vehicle has reached the end of the course or achieves a speed of 20 km/h.

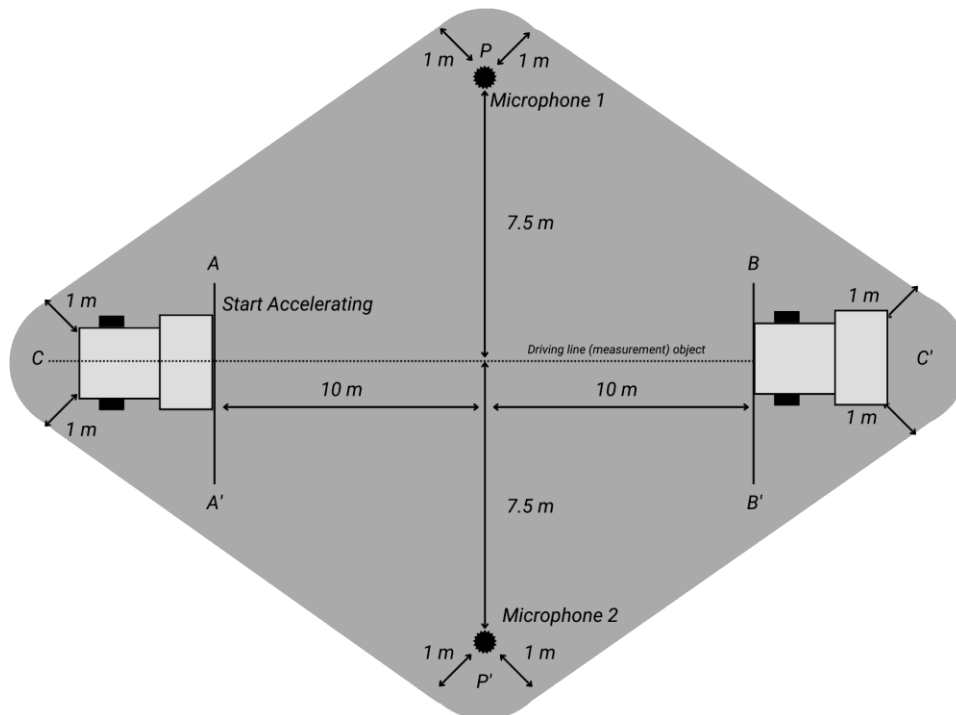

Figure 4.1: Measuring course for the acceleration test.



2nd series of measurements: accelerating without shifting gears (only applicable to vehicles with manual transmission)

- The length of the measuring course is 20 m (line AA' is located 10 m before the microphone line and line BB' is located 10m past the microphone line).
- The tested truck should drive along the driving line (line CC') in first gear with an idle speed setting. First gear is understood to mean the lowest possible gear ratio suitable for moving forwards on a flat public road while taking the vehicle's test mass into account. Special low gears for the use in terrain, maneuvering or crawling up hill etc. should not be used (please consult the manufacturer's user manual for further information about normal usage).
- The accelerator is pressed down as hard as possible when the start of the measuring course (line AA') is reached.

The accelerator is kept down until the rear of the vehicle reaches the end of the course and crosses line BB'. The accelerator is then released, the measurement is stopped, and the measurement values are read.

The measurement result is determined as follows:

The highest value from both measuring points of the 1st series of measurements is taken. The highest value from both measuring points of the 2nd series of measurements is taken. The highest value for the two runs is rounded to the nearest integer number in accordance with paragraph 3.3. This is the measurement result.

4.3 Compressed air noise

The compressed air noise for the following sources is measured in accordance with the procedures described in UN/ECE Regulation No R51-03 Annex 5 [3]

- Pressurizing the compressor and blowing off the pressure regulator.
- Blowing off or decompressing the service/foot brake.
- Blowing off or decompressing the hand brake.

At least three measurements of each of the three above-mentioned blow off events are made.

During the test, the sound from parts of the truck that are not continuously making sound (such as a fan) shall be ignored.

The measurement result is determined as follows:

The highest value from both measuring points of the 3 series of measurements is taken. The maximum of these two values is rounded to the nearest integer number in accordance with paragraph 3.3. From this value, 1 dB(A) shall be deducted. This is the measurement result.

4.3.1 *Alternative method for blowing off or decompressing the service/foot brake*

On the request of the participant, the compressed air noise test for service/foot



brakes can instead be conducted in the following way.

- The truck is driven at a constant speed of 20 km/h (step 1).
- After line AA' the service/foot brake is applied with a normal and constant force. The truck shall stop before line BB' (step 2).
- The compressed air pressure in the brake chamber is recorded, either by manual instrumentation or by reading out from the trucks On-Board Diagnostic data. The average brake pressure from the moment the brake is applied until the truck has stopped is the target pressure for step 4 (step 3).
- The stationary test for compressed air release due to service/foot brake decompression, as described in paragraph 4.3 is conducted, with the amount of force applied to the brake to give the target brake pressure as found in step 3 (step 4).
- The test is repeated and measured at least 3 times. The highest of the 3 measured values among these is rounded to the nearest integer number in accordance with paragraph 3.3. Because of the measurement uncertainty, this rounded number is reduced with 1 dB(A). This is the measurement result.

During the test, the sound from parts of the truck that are not continuously making sound (such as the fan) is ignored.

4.4 Reversing alarm system and blind spot warning system

The measurement is only carried out if the system can be used when maneuvering during loading and unloading. If applicable, the measurement will be carried out in "PEAK mode", which automatically reduces the volume emitted by the warning signal. If the system is not present or is switched off automatically in "PEAK mode", the measurement does not need to be taken. When the truck is equipped with an AVAS (Acoustic Vehicle Alerting System) and AVAS is on when the vehicle is stationary, then AVAS is part of the reversing alarm system test.

The following procedure shall be completed for measuring the sound signal:

- Only the truck without trailer or semi-trailer will be measured.
- The truck is stationary with powertrain deactivated during the test, and the truck state is such that the relevant acoustic signaling systems are in operation.
- In case the truck is equipped with an AVAS compliant with the UN/ECE Regulation No 138, it shall not be interfered with. It shall operate as designed by the manufacturer during the reversing alarm system test as well as the turn right (blind spot) test.

The reversing alarm system and turning right (blind spot) warning system must be tested separately. See figures 4.2 – 4.4 for the measurement setups.

4.4.1 Reversing alarm system:

During the transitional provisions period (paragraph 2.7) method A or B for the



reversing alarm system can be used.

4.4.1.1 Method A:

- The sound from the reversing alarm system is measured three times at 7.5 m from the rear of the vehicle at the height of 1.2 m above the road surface (figure 4.3) (signal duration 10 s for each measuring).
- The intermediate results are the highest values from each measurement and rounded to the nearest integer in accordance with paragraph 3.3.

4.4.1.2 Method B:

The sound from the reversing alarm system is measured three times at 7.5m from the rear of the vehicle.

The maximum sound pressure level shall be sought within the range of 0.5 and 1.5 m above the road surface (figure 4.4), and the height, at which the maximum sound-pressure level was found to be fixed for the purpose of taking the measurements prescribed below.

- The sound pressure level shall be measured three times at that fixed height for a duration of at least 10 seconds.
- The intermediate results are the highest values from each measurement and rounded to the nearest integer in accordance with paragraph 3.3.

The measurement result for reversing alarm system method A or B is the maximum value of the three intermediate results.

4.4.2 Blind spot warning system:

The noise is measured at least three times at 7.5 m from the side of the vehicle, directly across from the cabin's rear (figure 4.2) (signal duration 10 seconds).

The intermediate results are the highest values from each measurement and rounded to the nearest integer in accordance with paragraph 3.3.

The measurement result for blind spot warning system is the maximum value of the three intermediate results.



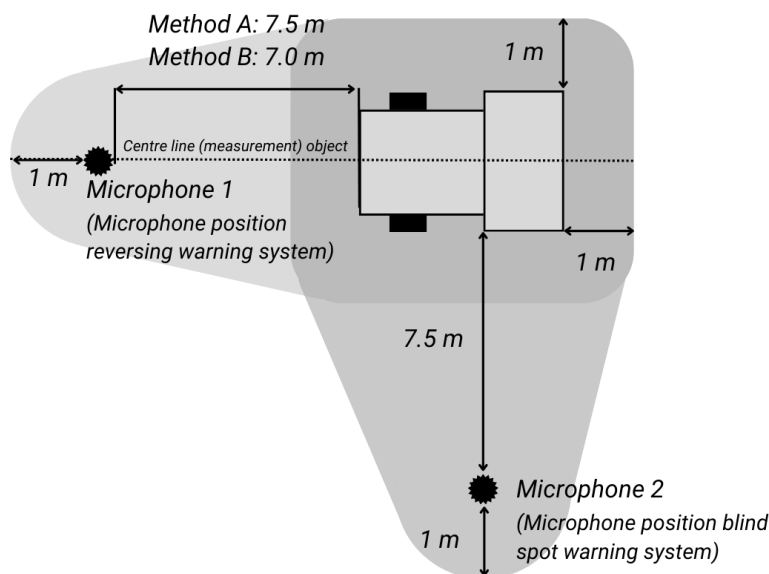

Figure 4.2: Microphone positions for measurements of reversing and blind spot warning systems

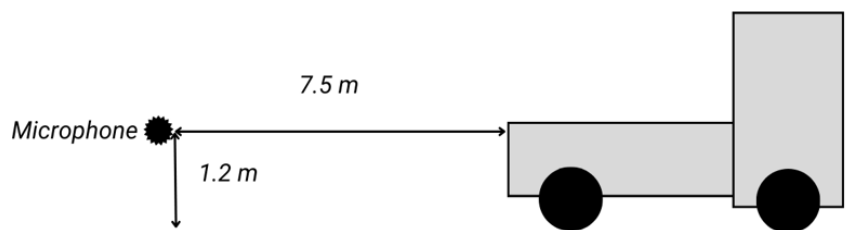

Figure 4.3: Microphone position for measurements of reversing warning system method A

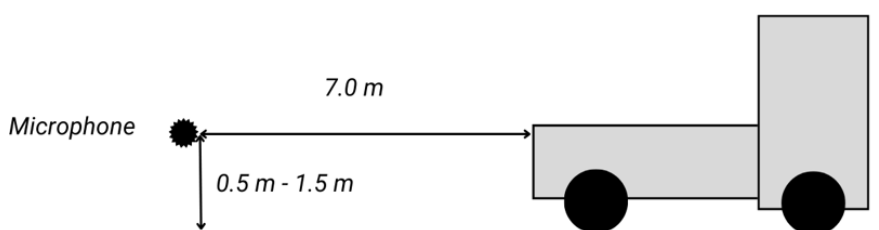

Figure 4.4: The height range of the microphone for measurements of reversing warning system method B

4.5 Pass-by sound

The pass-by sound for the trucks in motion is measured in accordance with the procedures described in UN/ECE Regulation No 51-03 Annex 3 [3].



Remarks relating to the use of UN/ECE Regulation No 51 for the certification of a QuietTRUCK:

- In deviation from parts of the text in UN/ECE Regulation No 51 dealing with “driving modes” and “urban driving”, the PEAK mode shall be activated during noise measurements (if applicable).
- RPM during the UN/ECE Regulation No 51 test: When determining the target RPM, calculations are done in accordance with UN/ECE Regulation No 51 with percentages of the RPM at maximum power output (n_{rated}). The RPM which is achieved in practice can be limited to $n_{max\ reduced}$ through intervention of the PEAK mode. The new target RPM for the UN/ECE Regulation No 51 test will now be $n_{max\ reduced}$.
- The testing area and the surface shall comply with the conditions set out in paragraph 3.2 and therefore may deviate from what has been stated in UN/ECE Regulation No 51-03 and/or ISO 10844.



5. Method of measurement for opening and closing doors of loading areas and cabins and air curtains for cargo bodies and sliding partitions, steps and strip curtains

This chapter describes the methods of measurement for several products including different variants of the doors.

For the cabin doors and the loading area doors made by the truck manufacturer, the measurement methods (paragraph 5.2) and limits (see paragraph 2.1) are different from those of the other doors made by the vehicle body builder (paragraph 5.1).

5.1 Vehicle loading area doors, hatches and hinged doors and air curtains of cargo bodies

5.1.1 Measuring arrangement

The methods of measurement for the loading area doors that are described below do not apply on doors made by the truck manufacturer.

The following set-up is used for this method of measurement (see figure 5.1):

- The engine and any other noise sources of the vehicle are switched off.
- If there is a tail lift present, it is in the lowest position on the ground or folded under the vehicle. In the case of a measurement on a top hatch the tail lift is to be aligned with the cargo floor.
- The measuring microphone is at a distance of 7.5m from the vehicle's edge opposite the center of the vehicle door or air curtain to be measured (hatch or door).

The microphone is 1.2m above the road surface.

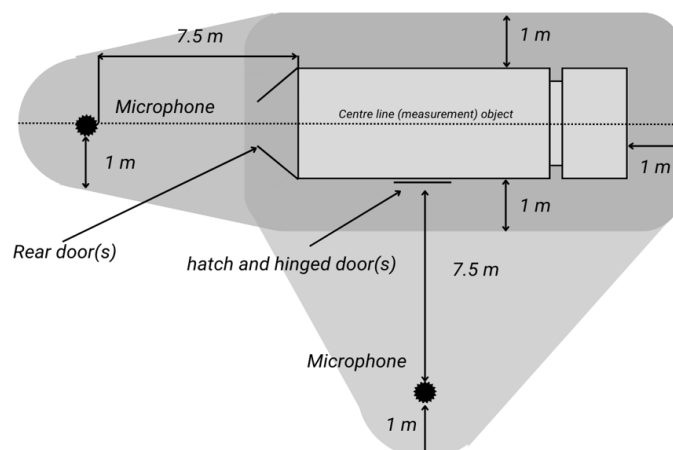

Figure 5.1 Microphone positions for measuring the noise of loading area doors, hinged, steps and air curtains for loading areas



5.1.2 Method of measurement

The following procedure shall be completed:

- The vehicle door (hatch or hinged door) is opened and closed by standing at arm's length from the vehicle door (hatch or hinged door) and grasping the door handle with an outstretched arm. A raised platform may be necessary to be able to operate the vehicle door (hatch or hinged door). The door is then opened until the handle is next to one's shoulder. If a door holder is present, the door shall be fully opened and secured with the door holder. The vehicle door (hatch or hinged door) is then closed with a single uniform motion.
- For hinged doors to the loading area, both doors are opened and closed in 1 cycle.
- For a roller door, the operator walks along in the direction of the door so that the complete motion of unlocking and sliding and relocking can be carried out
- The opening and closing of the vehicle door (hatch or hinged door) are repeated at least 5 times, waiting 5 seconds after closing each time before reading the noise level
- For air curtains, the doors of the cargo body are fully open, and the air curtain fans are turned to maximum power. Measurements are taken three times at 7.5m from the rear of the vehicle (at least 10 seconds between the measurements)

The energetic average value of the measured levels is rounded to the nearest integer number in accordance with paragraph 3.3. The rounded number is the measured value.

5.2 Cabin doors

The noise level of closing the cabin door(s) shall be measured at a prescribed speed. This speed is determined using the procedure described in paragraph 5.2.1. The method for measuring the noise level is described in section 5.2.2.

For a cabin which has different doors on the right and the left, both doors must be measured individually. For a cabin which has identical doors on both the left and the right, only the door on the driver's side must be measured.

5.2.1 Minimum Door closing speed

- The minimum speed required for the door to be fully closed shall be determined by using any of the methods described in 5.2.1.1 or 5.2.1.2.
- At least five successful door closing events shall be conducted and measured. The lowest speed of these is the minimum door closing speed.
- The hand shall release the door handle before the door is closed.

5.2.1.1 Automatic measurement of the door closing speed

- A special measuring device capable of measuring door closing speed may be used.
- The measuring device shall not interfere with the door closing.



- The measuring device shall be positioned to measure the speed between the tip of the door and the door frame and positioned at a point between 0 to 15,0 cm before the door is closed.

5.2.1.2 Manual measurement of the door closing speed

- The door closing speed v can be estimated by recording and measuring the time t and the distance s between two known sound peaks created during the door closing procedure.
- The first sound peak can be the sound produced when the door passes by and hits a certain object. This object can be a bell, a sheet of metal or any other object that provides a clearly recognizable sound in the sound recording. The object shall be placed at a distance d between the tip of the door and the door frame. The distance d should be above 5,0 cm and below 15,0 cm.
- The object shall not interfere with the door closing movement.
- The second sound peak comes from when the door is completely closed.
- The closing speed v is given by: $v = d/t$.
- A data acquisition device with a time resolution of maximum 0,01 second shall be used.

5.2.2 Measurement of door closing sound

The sound level of the cabin doors closing shall be measured at a prescribed target closing speed.

- The target closing speed shall be 25 % above the minimum closing speed found in paragraph 5.2.1.
- During the test, the door closing speed shall be measured according to either of the methods described in the paragraphs 5.2.1.1 or 5.2.1.2.
- The test shall be repeated multiple times until 5 tests are within +/-15 % of the target closing speed. The average closing speeds of these tests shall be within ± 5 % of the target closing speed. If the average closing speeds of these 5 measurements is not within this tolerance band, additional tests shall be performed until 5 tests are on average within the ± 5 % of the target closing speed.

The measurement result is the arithmetic average value of the readings (minimum of 5), rounded to an integer in accordance with paragraph 3.3.

The measuring microphone is 7.5m from the vehicle's edge opposite the centre of the cabin door or the loading area door made by the truck manufacturer to be measured, (see figure 5.2). The microphone is 1.2m above the road surface.



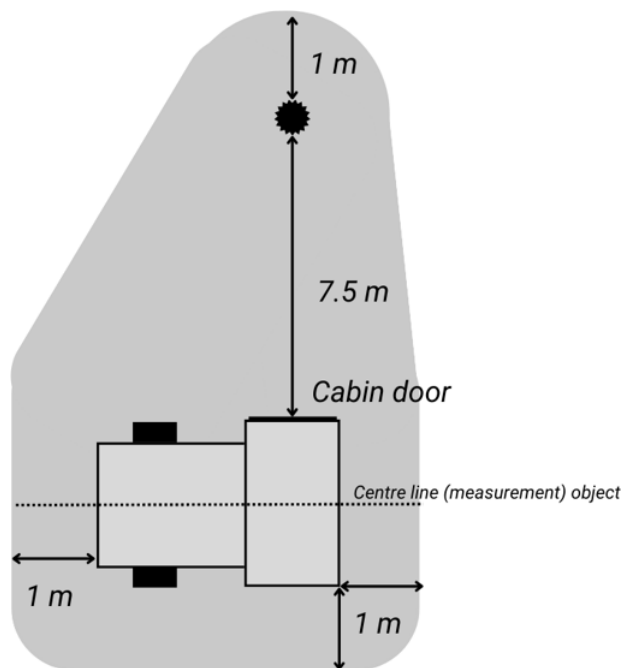

Figure 5.2 Microphone positions for measuring the noise of cabin doors and other doors made by the truck manufacturer

5.3 Roller doors and sliding panels

In addition to hatches and hinged doors, the cargo body area may also be closed by means of roller doors and sliding panels. If there are several roller doors or sliding panels, these shall be tested separately. Noise during opening and closing is evaluated as follows:

- The roller door or sliding panel is unlocked, fully opened, secured and then closed and locked again at a speed that is in line with practice.
- Sliding panels are slid completely open and then closed and locked again at a common operating speed.

See figure 5.3 for the microphone positions. If the roller door or sliding panel is mounted on the side of the vehicle, microphone 2 is located on the side of the vehicle where the actions take place. If the roller door or sliding panel is mounted to the rear, microphone 2 is located on the side where the drive system is located. The cycle is repeated and measured at least 5 times.

If there is a tail lift present, the tail lift is in the lowest position on the ground or folded under the vehicle.

The measurement result is the energetic average value of the readings (minimum of 5 per measuring point) at both measuring points, rounded to the nearest integer number in accordance with paragraph 3.3.



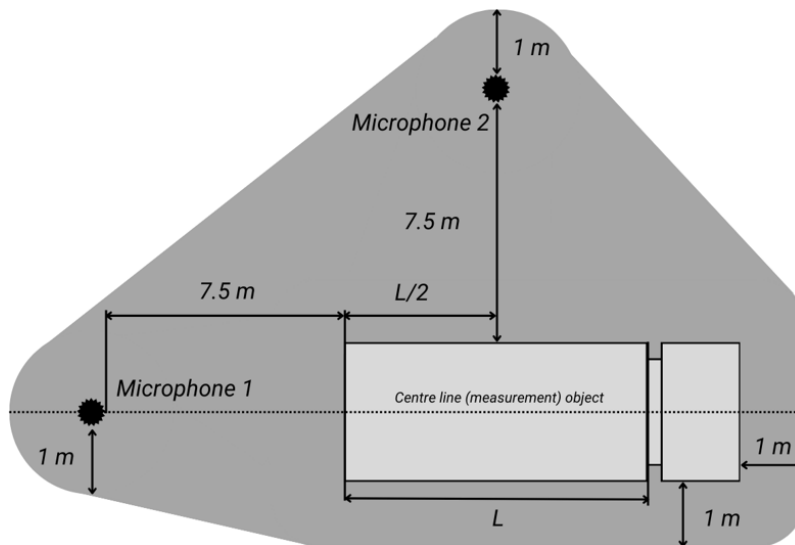

Figure 5.3 Microphone positions for measuring the sound of roller doors and sliding panels

5.4 Sliding partition wall

A sliding partition wall may be present in the cargo body. This kind of partition allows the cargo body to be divided into two paragraphs, so that cargo can be transported at two different temperatures. See figure 5.4 for the measurement setup

The measuring methods of the sliding partition wall are:

5.4.1 Moving

The noise produced while moving it is measured as follows:

- At the start of the cycle, the partition is located against the ceiling at the rear opening of the cargo body without being locked. After putting the partition into the correct position, it is moved to the front of the vehicle at a speed of 3 km/h. At the front, the partition is moved towards the ceiling without locking it to the ceiling. Here the tester waits for a few seconds, after which the partition is moved back to the rear of the vehicle and then moved towards the ceiling without locking it to the ceiling.
- The partition is slid against the stops both at the start of the rail and at the end of the rail.
- The cycle of moving the partition to the front and back is performed 3 times.
- The measurement result is the energetic average value of the readings (minimum of 3 per measuring point) at both measuring points, rounded to the nearest integer number in accordance with paragraph 3.3.
- See figure 5.4 for the measurement setup.
The tail lift, if present, may be at loading floor height during the measurement if this is necessary for the safety of the operator.



5.4.2 Unlocking and locking

The noise produced during unlocking and locking is measured as follows:

The following cycle is performed: The sliding partition wall is locked to the ceiling, then unlocked, and the partition is then moved to the position on the floor and locked in place. The partition is then unlocked again and moved towards the ceiling, where it is locked.

- For each locking point, the cycle is performed at least 3 times.
- The unlocking and locking of the partition on the floor are performed at a distance of $\frac{1}{4}L$, $\frac{1}{2}L$ and $\frac{3}{4}L$ from the rear opening of the cargo body. If the moving rail in the vehicle is shorter such that these distances cannot be reached, the points closest to these shall be used.
- The measurement result is determined as follows: the energetic average of 3 readings is calculated for each measuring point and collision point. The measurement result is the highest of the 6 energetic average values of the readings, rounded to the nearest integer number in accordance with paragraph 3.3.

If there is a tail lift present it is in the lowest position on the ground or folded under the vehicle. See figure 5.4 for the measurement setup.

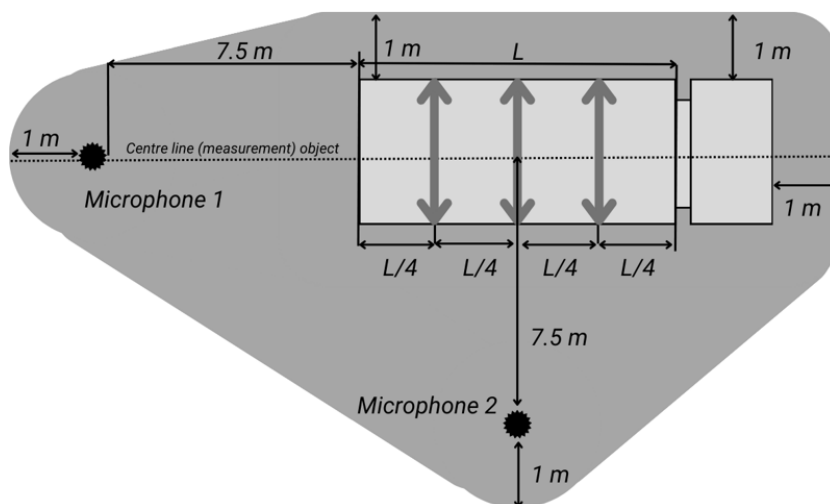

Figure 5.4 Microphone positions for measuring the sound of sliding partition wall

5.5 Steps

To enter the cargo body, certain vehicles are equipped with steps.

The noise produced while lowering and lifting the steps is measured as follows:

- The measuring microphone is at 7.5m opposite the center of the steps to be measured. The microphone is 1.2m above the road surface. See figure 5.1.
- If there is a tail lift present, it is in the lowest position on the ground or folded under the vehicle.



- The steps are in a transport position; the door(s) close to the step are completely open.
The steps shall be pulled out and brought into use condition at a speed consistent with normal practical use. The steps are then brought into transport position at a speed consistent with normal practical use. A pause of several seconds is added being brought the steps in the operating position and being placed in the transport position. Lowering and lifting the steps is one cycle.
- The above cycle is performed at least 5 times. Between the measurements, a pause of about 5 seconds should be added to read the noise level.
- The energetic average value of the measured levels is rounded to the nearest integer number in accordance with paragraph 3.3. The rounded number is the measured value.

5.6 Strip curtain

Apart from having an air curtain, a cargo body can also be closed off by a strip curtain.

Measurement setup strip curtain

Two microphones are placed around the vehicle, with its engine switched off (see figure 5.5):

- One at 7.5m from the rear, on the axis of the vehicle.
- One at the side of the vehicle, 7.5m from the axis and at the halfway point of the cargo body length ($L/2$).
- The microphones are 1.2m above the paved surface.

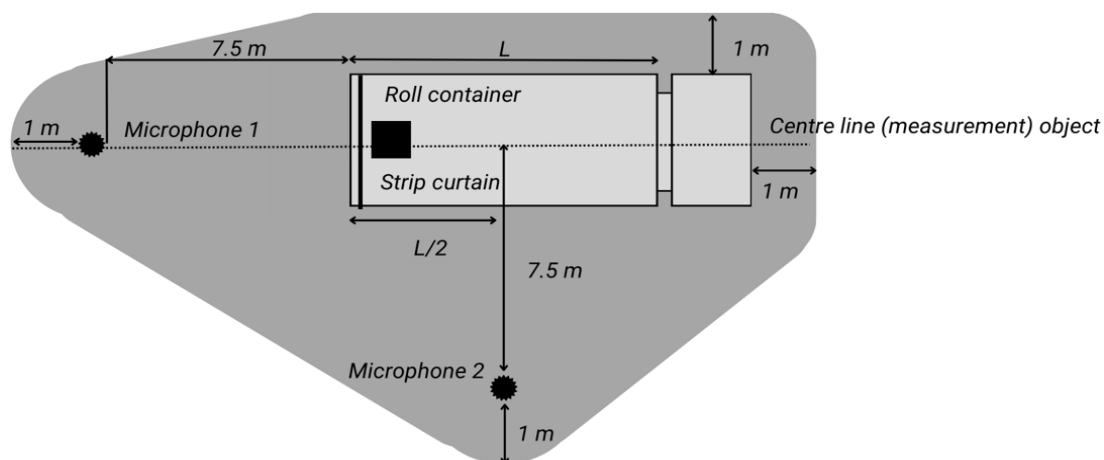

Figure 5.5 measurement setup strip curtain

The measuring methods of the strip curtain are:

5.6.1 Sliding

This can be a sliding strip curtain (perpendicular to the direction of travel) or a fixed curtain. In case of a sliding curtain, the sliding should be measured as follows:



- The doors to the cargo body in front of the strip curtain are fully open.
- If there is a tail lift present, it is in the lowest position on the ground or folded under the vehicle.
- During the measurement, the strip curtain shall be moved from being fully closed to being fully open and back and locked in place if possible. A pause of several seconds is added between fully open to closing. If the curtain consists of several sections, all the sections shall be tested
- If various types of strip curtains are present in the vehicle (opening to the right, opening to the left, opening in the middle, etc.), these shall be tested separately.
- The above cycle is performed at least 5 times. Between the measurements, a pause of about 5 seconds should be added to read the noise level.

The energetic average value of the measured levels is rounded to the nearest integer number in accordance with paragraph 3.3. The rounded number is the measured value.

See figure 5.5 for the measurement setup.

5.6.2 Moving in direction of travel

The sound produced while moving it in the direction of travel is measured as follows:

- At the start of the cycle, the strip curtain is located at the furthest position at the rear opening of the cargo body and locked in place.
- After the start of the measurement, the strip curtain is unlocked and moved as far as possible into the vehicle at a speed of 3 km/h. At the front, the strip curtain is locked in place. Following this, the tester waits a few seconds, after which the curtain is unlocked and moved back at a speed of 3 km/h to the rear of the vehicle and locked.
- The curtain is slid against the stops both at the start of the rail and at the end of the rail.
- The cycle of moving the curtain to the front and back is performed 3 times.
- The tail lift, if present, may be at loading floor height during the measurement if this is necessary for the safety of the operator.
- The measurement result is the energetic average value of the readings (minimum of 3 per measuring point) at both measuring points, rounded to the nearest integer number in accordance with paragraph 3.3.

See figure 5.5 for the measurement setup.

5.6.3 Collision with the strips

Moving the strips of the strip curtain in lateral direction is measured as follows:

- The doors to the cargo body in front of the strip curtain are fully open.
- If there is a tail lift present, it is in the lowest position on the ground or folded under the vehicle.
- A roll container with a steel superstructure (comparable to figure 5.7) with a minimum height of 1.5m is positioned on the center line of the vehicle in the cargo body against the strip curtain.
- The center strip is grabbed at a height of 1.5 m, pulled back 50 cm and then



released, see figure 5.6.

- The tester waits a few seconds between the strip movements to read the noise level.
- The above cycle is repeated at least 3 times.
- The measurement result is the energetic average value of the readings (minimum of 3 per measuring point) at both measuring points, rounded to the nearest integer number in accordance with paragraph 3.3.

See figure 5.5 for the measurement set up.

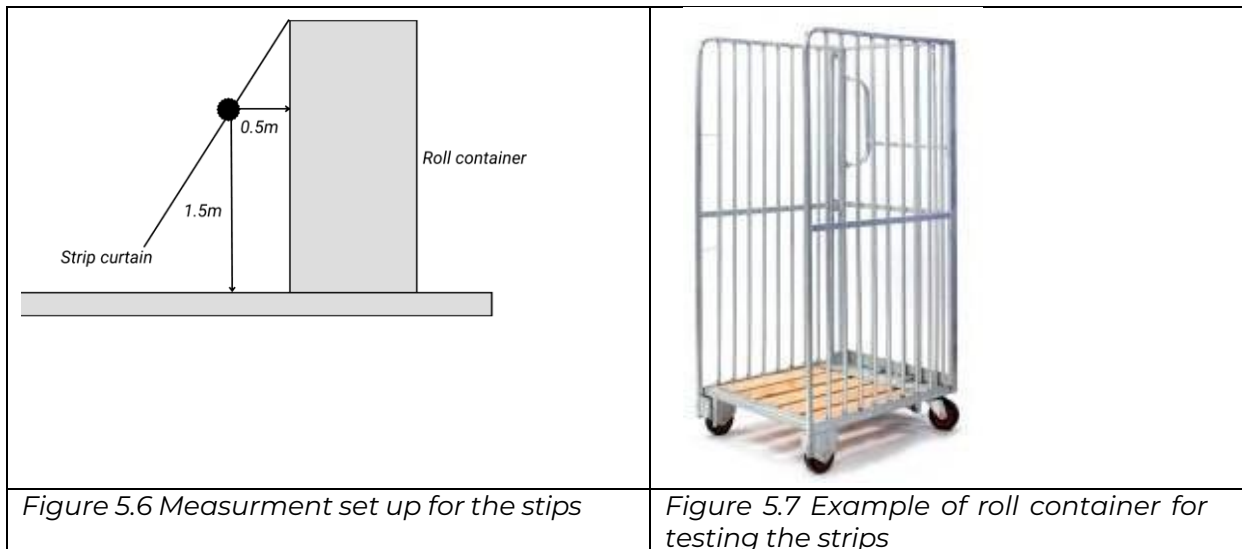

6. Methods of measurement for the tail lift and walls of vehicles and lashing devices

This paragraph deals with methods of measurement regarding the use of the tail lift, fastening the load and moving transport equipment over the tail lift, floor, and walls of the cargo body. All tests described in this paragraph are conducted with an empty cargo body.

6.1 Measuring arrangement

Two microphones are placed around the vehicle, with its engine switched off (see figure 6.1):

- One at 7.5m from the rear, on the axis of the vehicle.
- One at the side of the vehicle (tail lift operation side), 7.5 m from the axis and at the halfway point of the cargo body length ($L/2$).
- The microphones are 1.2 m above the paved surface.
- If the drive system is located on the other side of the vehicle than the controls, an extra measuring point is selected on that side as well as a measurement taken.

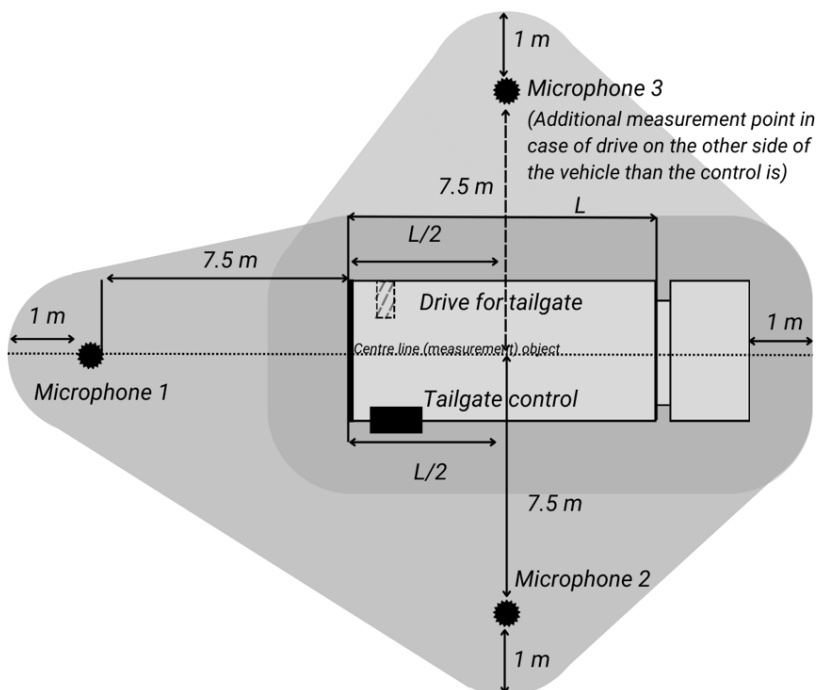

Figure 6.1 Microphone positions for measurements on the tail lift, cargo body and lashing devices



Tail lift measurement on a test setup

In addition to a noise measurement of a tailgate mounted on a vehicle, it is also permitted for the tail lift to be mounted on a test setup during the noise measurement. The test setup shall be representative of a vehicle.

- One microphone at 7.5 m from the rear, on the axis of the test setup.
- One microphone on the side of the test setup (tailgate control side), 7.5 m off-axis and opposite the center of the tailgate control.
- The microphones are 1.2 m above the pavement.
- If the drive system is located on the other side of the test setup than the side where the control is mounted, a measuring point is also selected on that side of the test setup when the measurement '6.2.1 opening and closing' is carried out. This measuring point is located 7.5 m from the centre line and opposite the center of the tailbord drive system.

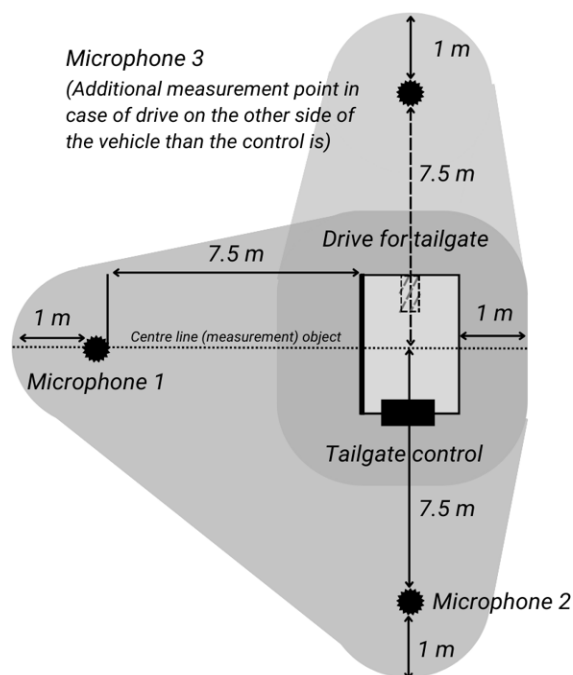

Figure 6.2 Microphone positions for measurements near the tail lift at a test setup

6.2 Tail lift

The tail lift is a platform at the rear of the vehicle that can be raised. It is used to load and unload goods in roll containers or pallet trucks from the cargo body floor level to street level and vice versa. The tail lift is hydraulically driven. The hydraulic pump is electrically powered. This paragraph describes the method of measurement for the power source of the tail lift and the roll-off stops.



6.2.1 Opening and closing

The method of measurement for opening and closing the tail lift is as follows:

- See paragraph 6.1 for the measuring points.
- The noise measurement is taken during a complete cycle of opening and closing the tail lift.
- The cycle is repeated and measured three times.
- The noise measurement begins as soon as the tail lift (in the closed position) is activated, followed by the complete lowering cycle, including any folding out, until the tail lift touches the ground. The tail lift shall lie on the ground so that a roll container can be rolled onto the tail lift. The folding-up cycle then follows until the tail lift is fully folded up. The measurement is stopped.
- For each measuring point, an energetic average value of the readings at the measuring points (minimum of 3 per measuring point) is defined and rounded to the nearest integer number in accordance with paragraph 3.3.
- In the event that the drive system is located on the other side of the vehicle or test setup than the side where the control is mounted also from the additional measurement point shall an energetic average value of the readings at the measuring points (minimum of 3 per measuring point) be defined and rounded to the nearest integer number in accordance with paragraph 3.3.
- The measurement result is the highest energetic average value from each measuring point.

6.2.2 Roll-off stop

The roll-off stop is a small folding barrier built into the tail lift near the rear edge of the tail lift. In its raised position, this barrier prevents a roll container from rolling off the tail lift.

The method of measurement for the roll-off stop is as follows:

- The tail lift is in its lowest position.
- See paragraph 6.1 for measuring points. Microphone 2 is on the same side of the vehicle or test setup than the roll-off stop that is measured.
- The roll-off stop is folded down and raised at least five times using one's foot. A pause of several seconds is added between folding down and raising.
- If there are several ways to lock the stop in place, all the methods shall be tested individually.
- For each measuring point an energetic average value of the readings at the measuring points (minimum of 5 times raising and pushing down) defined and rounded to the nearest integer number in accordance with paragraph 3.3.
- If there are several ways to lock the stop in place, all methods shall be tested. For those measurements, there shall be for each measuring point an energetic average value of the readings at the measuring points (minimum of 5 times raising and pushing down) defined and rounded to the nearest integer number in accordance with paragraph 3.3.
- The measurement result is the higher of the energetic average values of the



readings at each measuring point, rounded to the nearest integer in accordance with paragraph 3.3.

6.3 Rolling noise

When rolling transportation equipment over a tail lift, through the cargo body or over a plate bridging a difference in height, both the transportation equipment and the plate or lift can create noise. This paragraph describes a method of measurement for evaluating only the noise radiated by the plate or lift. To obtain a collision comparable with practical conditions, a modified 'quiet' roll container is used as shown in figure 6.3. The modified roll container shall be fitted with four hard (minimum shore D 70) standard plastic wheels (no rubber tyres) with a diameter of 100 mm. The roll container is loaded with a sandbag weighing 25 kg.

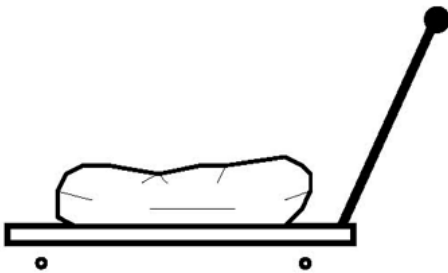

Figure 6.3: Schematic representation of a 'quiet' roll container with hard (minimum shore D 70) standard plastic wheels (no rubber tyres) with a diameter of 100 mm and a 25 kg sandbag as load.

6.3.1 Rolling over the tail lift

The method used to evaluate the noise produced in rolling over the tail lift is as follows:

- The tail lift is horizontal in its highest position, extending from the floor of the vehicle.
- The rolling speed shall be 3 km/h.
- See paragraph 6.1 for measuring points.
- The 'quiet' roll container (see figure 6.3) is rolled at least three times from left to right and back (perpendicular to the driving direction) and at least three times from front to rear and back (in the driving direction) without rolling over the gap between the tail lift and the cargo body. (back and forth is 1 cycle).
- If the platform of the tail lift consists of several components, divergent material or surface structures, on all the components, divergent material or surface structures shall be rolled during the measuring.
- Of all the readings from both measuring points, minimum of 6 per measuring point, the energetic average value shall be defined and rounded to the nearest integer number in accordance with paragraph 3.3.
- The measurement result is the energetic average value of the readings rounded



to the nearest integer number in accordance with paragraph 3.3.

6.3.2 Rolling over the floor of the cargo body

The method used to evaluate noise production while rolling over the floor of the cargo body of the vehicle is as follows:

- The tail lift is horizontal in its highest position, extending from the floor of the vehicle or test setup.
- See paragraph 6.1 for measuring points.
- The doors are open as wide as possible.
- The 'quiet' roll container (see figure 6.3) is rolled into the cargo body, starting at the entrance to the cargo body, to the rear panel and back.
- The rolling speed shall be 3 km/h.
- If the floor consists of several components, different material or surface structures over all the components, different material or surface structures shall be rolled.
- The measurement cycle is carried out and measured at least three times (back and forth is 1 cycle).
- There shall be no collisions with the wall while rolling.
- The measurement result is the energetic average value of the readings (minimum of 3 per measuring point) at both measuring points, rounded to the nearest integer number in accordance with paragraph 3.3.

6.3.3 Rolling over transitions (e.g. from tail lift to cargo body floor)

The method used to evaluate the noise occurring while rolling over the gap between the tail lift and the cargo body floor is as follows:

- The 'quiet' roll container (see figure 6.3) is rolled onto and off the tail lift from the cargo body, in the driving direction of the vehicle.
- The rolling speed shall be 3 km/h.
- See paragraph 6.1 for measuring points.
- The measurement cycle is carried out and measured at least three times (back and forth is 1 cycle).
- The measurement result is the energetic average value of the readings (minimum of 3 per measuring point) at both measuring points, rounded to the nearest integer number in accordance with paragraph 3.3.

6.4 Noise of collision with walls of the cargo body

6.4.1 Wall

The noise radiated by the wall of the cargo body because of colliding roll containers, for example, is evaluated as follows:

- See figure 6.4 for the measuring points. Microphone 2 is on the same side of the vehicle as the side wall where the collision is.
- If there is a tail lift present, it is in the lowest position on the ground or folded under the vehicle.
- The collision is simulated using a ball on a cord, which is released at a distance



from the side wall and then collides with the wall (see figure 6.6). By using a ball (that radiates little noise) instead of a roll container, for example, only the noise radiated from the wall is measured, in analogy with the rolling noise measurement (see paragraph 6.4). In principle, measurements are taken on one side of the vehicle only.

- A steel ball weighing 1 kg hangs on a cord. The distance from the center of the ball to the fastening point (directly above the collision point) of the cord is 1m. The ball is released at 10 cm from the center of the steel ball and the wall (see figure 6.4). The ball is caught after the collision. The sound level is read.
- A pause of a few seconds is added between the collisions to read the noise level.
- If there are wheel housings in the cargo body, a single collision point on the vertical wall of the wheel housing is chosen. The fastening point of the cord is kept directly above the collision point on the wheel housing. The collision is equivalent to the collision with the wall.

The collision points are 15cm above the floor and at a distance of $1/4L$, $1/2L$ and $3/4L$ from the rear opening of the cargo body.

- For each collision point, the measurement will be done three times.
- The measurement result is determined as follows: the energetic average of 3 readings is calculated for each measuring point and collision point. The measurement result is the highest of the 6 energetic average values of the readings, rounded to the nearest integer number in accordance with paragraph 3.3.

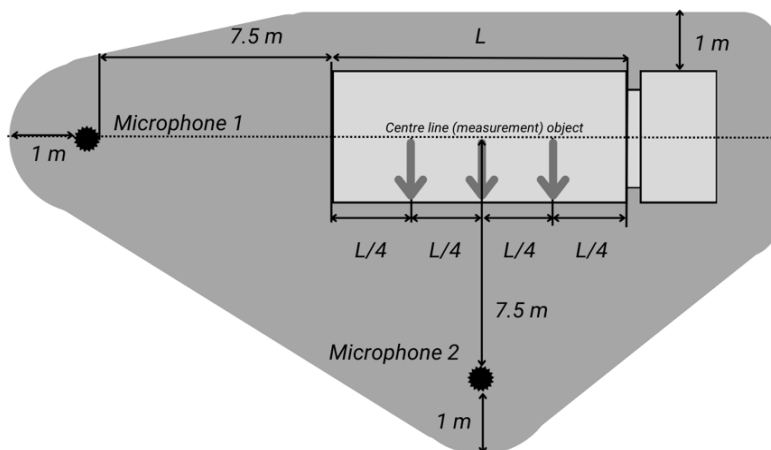

Figure 6.4 Measurement set up for measuring the lift sidewall

6.4.1.1 Additional components on the wall

Additional products, such as cargo rails, may be mounted on the wall of the loading area of vehicles. If these products protrude from the collision points at the height of 15 cm according to paragraph 6.4.1, these products shall be additionally tested.

To assess the sound radiation of these products, the procedure described in paragraph 6.4.1 shall be followed, with the addition:

- The collision points are at a distance of $1/4L$, $1/2L$ and $3/4L$ from the rear



opening of the cargo body on a height that matches the center of the product. When the product is not on a distance of $1/4L$, $1/2L$ and $3/4L$ from the rear opening of the cargo body then the collision points are as close as possible to these dimensions.

- A shorter length of the cord is allowed if, due to the position of the product on the wall, there is no space available to use a cord length of 1 m. If the length of the cord needs to be shortened, the distance from the ball to the side wall may be reduced proportionately. For example, with a cord length of 50cm, the distance from the center of the ball to the product may be 5cm.

6.4.2 Front end

- See figure 6.5 for the measuring points.
- If there is a tail lift present, it is in the lowest position on the ground or folded under the vehicle.
- A steel ball weighing 1 kg hangs on a cord. The distance from the centre of the ball to the fastening point (directly above the collision point) of the cord is 1m. The ball is released at 10cm from the front end (see figure 6.6). The ball is caught after the collision. The noise level is read.
- A pause of a few seconds is added between the collisions to read the sound level.
- For each collision point, the measurement will be done three times.
- The collision points are 15cm above the floor and at a distance of $1/3L$ from the side walls of the cargo body.
- The measurement result is determined as follows: the energetic average of 3 readings is calculated for each measuring point and collision point. The measurement result is the highest of the 4 energetic average values of the readings, rounded to the nearest integer number in accordance with paragraph 3.3.

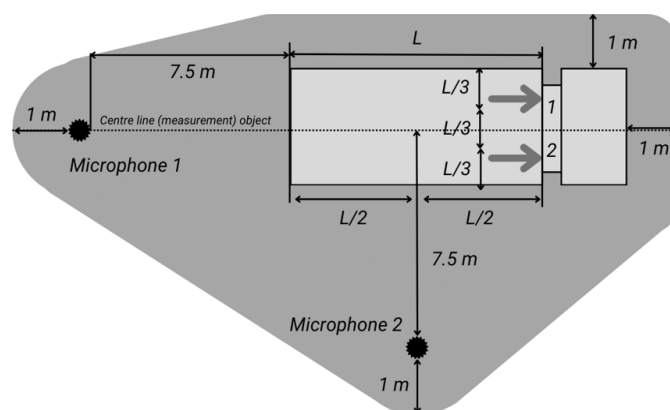

Figure 6.5 Measurement set for measuring the front end of a vehicle

6.4.2.1 Additional components on the front end

Additional products, such as transport refrigeration, may be mounted on the front end of the loading area of vehicles. If these products protrude from the collision



points at a height of 15cm (paragraph 6.4.2), these products shall be additionally tested.

To assess the sound radiation of these products, the procedure described above shall be followed, with the addition:

- The collision points are at a distance of $1/3L$ from the side walls of the cargo body on a high that match with the center of the product. When the product is not on a distance of $1/3L$ from the side walls of the cargo body then the collision points are as close as possible to these dimensions.
- A shorter length of the cord is allowed if, due to the position of the product on the wall, there is no space available to use a cord length of 1m. If the length of the cord needs to be shortened, the distance from the ball to the side wall may be reduced proportionately. For example, with a cord length of 50cm, the distance from the center of the ball to the component may be 5cm.

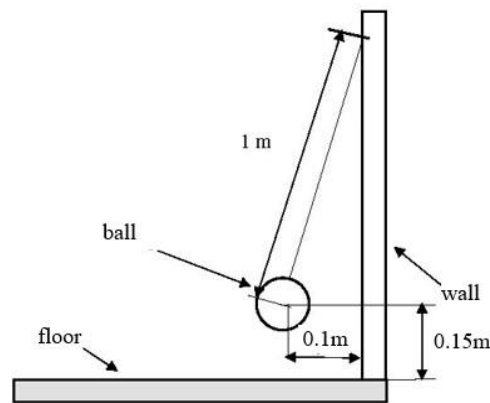

Figure 6.6 Setup from the steel ball on a cord for measuring the wall and front end

6.5 Load fastening system

Straps and clamping blocks are used to secure the load in the cargo body. Setting and releasing the load fasteners creates noise in the fastener itself and the wall, floor or ceiling of the cargo body. The following methods are intended to determine the noise resulting from securing, strapping down, and collisions.

6.5.1 Straps

The method of measurement is as follows:

- See figure 6.1 for the measuring points.
- If there is a tail lift present, the tail lift is to be aligned with the cargo floor.
- A cycle consists in:
 - Attach the hooks of the straps to both fastening rails of the cargo body.
 - Pull the strap on tension by pulling the strap or with the tensioner (like a ratchet) when this is part of the straps system.



- Release the tension on the strap.
 - Remove the hooks of the straps from the fastening rails.
- This cycle is carried out at least 3 times for each point (3 times in the front, 3 in the middle and 3 in the back).
- The measurement result is determined as follows: the energetic average of 3 readings is calculated for each measuring point and fastening point. The measurement result is the highest of the 6 energetic average values of the readings at both measuring points, rounded to the nearest integer number in accordance with paragraph 3.3.

6.5.2 Clamping blocks placing

The method of measurement is as follows:

- See figure 6.1 for the measuring points.
- If there is a tail lift present, the tail lift is to be aligned with the cargo floor.
- Place the clamping block in both fastening rails in the cargo body.
- Click the clamping block into place. It is then released again.
This cycle is carried out at least 3 times for each point (3 times in the front, 3 in the middle, and 3 in the back).
- The measurement result is determined as follows: the energetic average of 3 readings is calculated for each measuring point and fastening point. The measurement result is the highest of the 6 energetic average values of the readings at both measuring points, rounded to the nearest integer number in accordance with paragraph 3.3.

6.5.3 Clamping blocks moving in high

Some types of clamping blocks can in the fastening rails be changed in the high. When this is possible the measuring of 6.5.3 should be performed. When the clamping blocks can be placed in the fastening rail and changed in the high the measuring according to 6.5.2 and 6.5.3 shall be performed.

The method of measurement is as follows:

- See figure 6.1 for the measuring points.
- If there is a tail lift present, the tail lift is to be aligned with the cargo floor.
 - The cycle starts after the clamping blocks have been placed and locked in the lowest position of the fastening rails.
 - A cycle consists of:
 - Unlock clamping blocks
 - Moves the clamping blocks at a speed that corresponds to normal practical use to the highest possible point of the fastening rails
 - Lock the clamping blocks.
 - After a few seconds, the clamping blocks are unlocked and moved to the lowest possible point of the fastening rails at a speed that corresponds to practice.
 - The clamping blocks are locked in the lowest possible point of the fastening rails.



- This cycle is carried out at least 3 times for each point (3 times in the front, 3 in the middle and 3 in the back).
- The measurement result is determined as follows: the energetic average of 3 readings is calculated for each measuring point and fastening point. The measurement result is the highest of the 6 energetic average values of the readings at both measuring points, rounded to the nearest integer number in accordance with paragraph 3.3.



7. Method of measurement for shopping trolleys and pallet trucks

7.1 Rolling noise

To evaluate the noise of shopping trolleys, manually and electrically operated pallet trucks while rolling, a smooth surface is used with standardized irregularities applied to it. The surface itself should not radiate noise.

The irregularities consist of steel strips, preferably glued to the surface, in accordance with figure 7.1. A different attachment method may be used, possibly combined with glue. The transport equipment is measured unloaded.

Measuring course

The measuring course for these three types of transport equipment is as follows (see figure 7.1):

- The surface shall consist of smooth asphalt or concrete.
- The irregularities consist of four rectangular metal strips 30 mm wide and 5 mm high, as indicated in figure 7.1.
- The strips are at least 1.5 times the width of the transport equipment in length.
- The strips are preferably glued or attached over the entire length of the surface.
- The four strips are applied to the measuring course in parallel at a distance of 2m from each other
- The test course is at least 1.5 times as wide as the transport equipment being evaluated.
- The length of the measuring course is 12m.

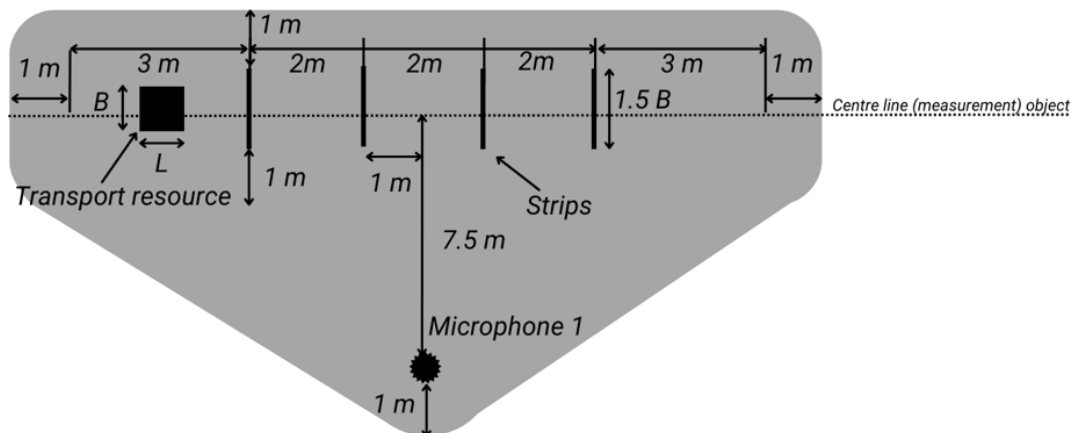

Figure 7.1: Situation for measuring the rolling noise of roll containers, pallet trucks and shopping trolleys

Measurement procedure

The measurement procedure is as follows:

- See figure 7.1 for the measuring point.
- The transport equipment is unloaded.



- When measuring the pallet truck, the fork is in its lowest position.
- The measurement consists of 2 cycles:
 1. The transport equipment is rolled with the front (swivel castors) over the course at a walking speed of 3 km/h.
 2. The transport equipment is rolled with the rear end (fixed castors) over the course at a walking speed of 3 km/h.
- All wheels shall pass over the irregularities.
- Per cycle the measurement course is covered at least 3 times.
- For each cycles the energetic average value of the readings (minimum of 3) at the measuring point shall be determined, this is the intermediate results.
- The measurement result is the highest intermediate results rounded to the nearest integer number in accordance with paragraph 3.3.

7.2 Lowering and raising electrically and manually operated pallet trucks

The method of measurement applied to lowering and raising electrically and manually operated pallet trucks is the one used for evaluating the lowering and raising of a forklift truck. See paragraph 9.2 for this.



8. Method of measurement for roll containers, rollies and dollies

The roll container is a transporter for a large range of products. The roll container has a folding base and sides that can be hinged, so that the empty roll containers can be nested together for moving. The roly (half Europallet) and the dolly (quarter Europallet) are wheeled pallets for transporting crates and boxes, and are used, among other things, for direct positioning. The empty rollies and dollies are stacked for moving around.

8.1 Rolling noise

8.1.1 Loaded

The method of measurement for rolling noise is identical to that used for shopping trolleys and pallet trucks described in paragraph 7.1, with the difference that the strips are 3mm high. The roll container and the roly are loaded with a weight of 100kg; the dolly is loaded with a weight of 50kg. If several loading shelves can be placed in a roll container, roly or dolly, the test shall be performed without additional loading shelves and with 75% of the maximum number of loading shelves (number shall be rounded up). When using several loading shelves, the load shall be evenly distributed with a minimum of 10kg.

8.1.2 Rolling nested roll containers

The method of measurement involves rolling three nested roll containers in accordance with the method of measurement described in paragraph 8.1.1 but unloaded.

8.1.3 Rolling empty roll containers that cannot be nested

The method of measurement for rolling noise is identical to that used for shopping trolleys and pallet trucks described in paragraph 7.1, with the difference that the strips are 3mm high. If several loading shelves can be placed in a roll container, the test shall be performed without additional loading shelves and with 75% of the maximum number of loading shelves (number shall be rounded up).

8.1.4 Rolling stacked rollies and dollies

The rollies and dollies are rolled along the measuring course in accordance with the method of measurement described in paragraph 8.1.1, with 5 stacked but unloaded rollies or dollies.

8.2 Colliding/nesting roll containers

For the collision noise, the method of measurement involves nesting the roll containers. One roll container is rolled into two already nested roll containers, as is customary with nesting.



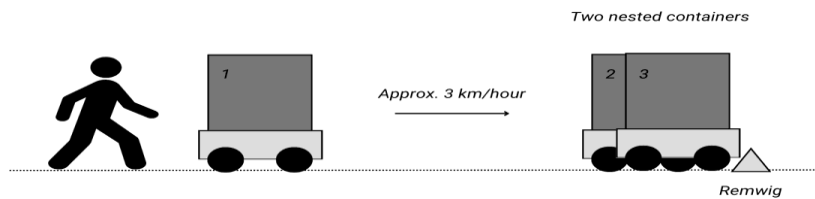

Figure 8.1 The measuring arrangement of colliding/nesting

The measurement procedure is as follows:

- Roll container 1 is pushed against the nested roll containers 2 and 3, at a speed of 3 km/h, as is customary with nesting. The two nested roll containers should be stopped by a braking chock or a similar obstacle.
- The transport equipment is unloaded and of the same type.
- The microphone is at 7.5m from the collision point on a line perpendicular to the rolling direction.
- The test is repeated at least three times.
- The measurement result is the energetic average value of the readings (minimum of 3) at the measuring point, rounded to the nearest integer number in accordance with paragraph 3.3.

8.3 Placing and removing additional loading shelves

- No additional loading shelves are present in a roll container.
- During the measurement, an additional loading shelf is placed; after placing it, the tester waits a few seconds, after which the additional loading shelf is removed.
- The cycle is repeated at least 3 times.
- The microphone is 7.5m from the center point of the roll container.
- The measurement result is the energetic average value of the readings (minimum of 3) at the measuring point, rounded to the nearest integer number in accordance with paragraph 3.3.

8.4 Stacking rollies and dollies

The empty rollies and dollies are stacked for moving around.

The measurement procedure is as follows:

- The transport equipment is unloaded and of the same type.
- The microphone is placed at 7.5m from the center point of the stationary roly or dolly.
- An empty roly or dolly is lifted and placed on a stationary roly or dolly from standing height, while measuring the noise level. The next roly or dolly is then lifted and placed on the two stacked rollies or dollies from standing height, and the noise level is measured. Finally, one more roly or dolly is placed on the stacked rollies or dollies, and the noise level is measured.
- The measurement result is the energetic average value of the 3 measurements, rounded to the nearest integer number in accordance with paragraph 3.3.



9. Method of measurement for forklift trucks and mobile forklift trucks

A mobile forklift truck differs from other forklift trucks in that it is connected to the rear of the vehicle during transport. There are versions for which the operating personnel are not seated on the forklift but walk behind it. There are no functional differences. Like a forklift truck, a mobile forklift truck has its own drive system. Forklift trucks and mobile forklift trucks are evaluated in the same manner in terms of noise production during driving and lifting. Because of peak noise, collisions are important when driving over irregularities. A driving test is therefore proposed in which forklifts are driven over several standardized irregularities, see figure 7.1. For a mobile forklift truck, the (collision) noise that occurs when connecting it to the vehicle is also measured.

9.1 Driving

- The requirements for the measuring course and the forklift to be measured are:
- See figure 7.1 for the layout of the measuring course
- At least another 10m smooth surface shall be available before and after the measuring course with irregularities
- The forklift is unloaded
- The forks are in their lowest position, so that the scoops of the pallet truck do not touch the strips
- The forklift is tested in its standard version as described by the manufacturer
- The engine and hydraulic system of the forklift truck shall be within the limits of the operating temperature indicated by the manufacturer.

9.1.1 Measurement procedure

The measurement procedure is as follows:

- The forklift truck is driven over the measuring course at a constant speed of 13 ± 2 km/h or, if this is not possible, the maximum speed indicated by the supplier.
- For a forklift truck with a manual gearbox, the highest gear is selected.
- For mobile forklift trucks that are operated while walking, the driving speed is 3 km/h.
- Each side of the forklift truck (left and right) is measured at least 3 times.
- The measurement result is the energetic average value of the readings (minimum of 6) at both measuring points, rounded to the nearest integer number in accordance with paragraph 3.3.



9.2 Evaluation of lifting

Measurements are taken at 4 measuring points (front, side (2), rear) around the stationary forklift. The evaluation distance of 7.5m to the microphone is from the vertical projection of the geometric centre of the forklift to the reflecting surface.

The following measurement procedure for evaluating the lifting sound shall be completed:

- The forklift lifts a load equal to 70% of the actual capacity (permitted by the manufacturer) from minimum to maximum height at maximum acceleration
- Each side of the forklift truck is measured at least 2 times
- The measurement result is the energetic average value of the readings (minimum of 8) at the measuring points, rounded to the nearest integer number in accordance with paragraph 3.3

9.3 Evaluation of connecting mobile forklift truck

This test uses an unloaded vehicle. The doors and panels of the vehicle are closed. Measurements are taken in two directions (see figure 9.1).

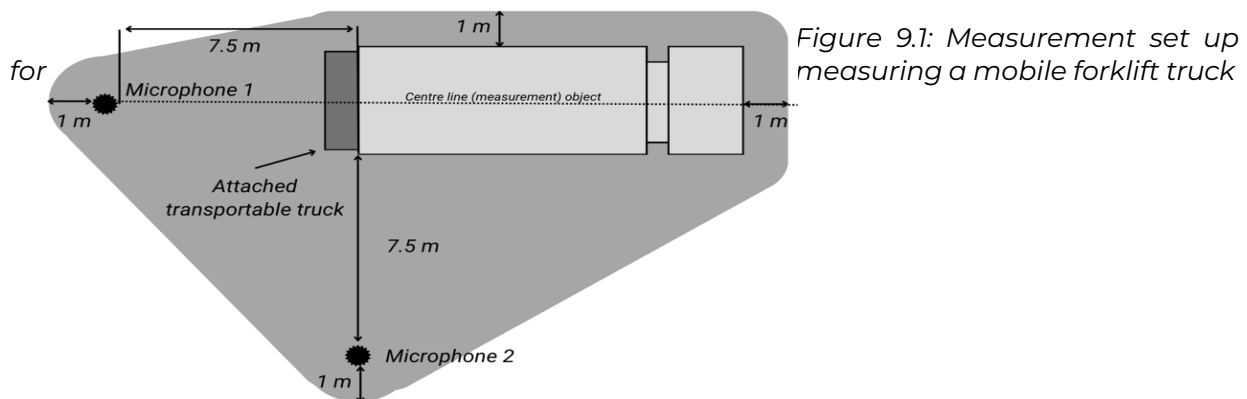

The following measurement procedure shall be completed to evaluate the noise when connecting and disconnecting the mobile forklift truck:

- The vehicle is placed in the measuring position, and its engine is switched off.
- The measurement begins before the engine of the mobile forklift truck starts on the vehicle
- The mobile forklift truck is unloaded and placed on the ground, after which it is reversed until the forklift is clear of the vehicle.
- The mobile forklift truck is then driven back into the vehicle clamp.
- The truck is put in the transport position and locked.
- The engine is switched off and the measurement stops.
- Measurements are taken at least three times. The measurement result is the energetic average value of the readings (minimum of 6) at both measuring points, rounded to the nearest integer number in accordance with paragraph 3.3.



10. Method of measurement for transport refrigeration

Refrigeration is used to keep perishable goods at the correct temperature during transport [6]. The following systems are distinguished:

10.1 Types of transport refrigeration

10.1.1 Refrigeration system with integrated combustion engine

A refrigeration system with a compressor, one or more evaporators, a control valve, a condenser, and an integrated combustion engine that provides power. The unit, possibly excluding the evaporator(s), is placed in an enclosure that is attached against the front end of the cargo body or underneath the floor. An electric motor may also be present within the enclosure to power the compressor when the trucks engine is switched off. The electric motor is then connected to the public mains.

10.1.2 Refrigeration system without separate combustion engine

A refrigeration system with a compressor, one or more evaporators (possibly in the cargo body), a control valve, and a condenser. The unit is powered by the trucks engine or by a separate diesel engine mounted underneath the loading body, or the unit is connected directly to the vehicle's battery. The following are distinguished:

10.1.2.1 Electrical systems in which a generator is powered directly or indirectly by the trucks engine. For a direct drive system, the generator is powered by the trucks engine without any other components. One example of an indirect drive system is having a hydraulic transmission mounted between the trucks engine and the generator.

10.1.2.2 Systems in which the mechanical compressor of the refrigeration unit is powered directly by the trucks engine.

10.1.2.3 Electrical systems started at under 10.1.2.1 with additional support from a (quickly exchangeable) powerpack ((diesel) generator set). The latter consists of a (diesel) engine with a generator that can power the refrigeration system when the trucks engine is switched off.

10.1.2.4 Systems in which the original integrated diesel engine has been removed and mounted in a separate diesel engine enclosure underneath the cargo body.

10.1.2.5 Systems in which the unit is connected directly to the vehicle's battery.

10.1.3 Refrigeration system based on an "open" gas system

A cooling system with a control valve in which gas (e.g. nitrogen or carbon dioxide) evaporates directly in the cargo body or indirectly in one or more evaporators.

10.1.4 Refrigeration system with eutectic mass

In this system, a eutectic mass is installed in the body instead of the evaporator. The eutectic refrigerant is usually frozen when the vehicle is stationary (at night). The cooling occurs because the cooled air is heavier and floats down in the cargo body. It is also possible to use a fan in the cargo body to lead air along the eutectic mass and cool it. This system is expected to be sufficiently quiet in terms of the PEAK noise issue and will not be discussed any further.



If the vehicle is equipped with a “PEAK mode” switch, the tests can also be performed with “PEAK mode” activated. “PEAK mode” shall be driver independent. The driver shall not be able to influence “PEAK mode” either, see also 10.4.

10.2 Measuring arrangements

The vehicle with transport refrigeration is placed in the middle of the measuring surface.

10.2.1 Measuring points for refrigeration unit at front end

If the refrigeration unit is mounted to the front end of the vehicle, measurements are taken in 2 directions (angular width is 90°) at the front of the transport refrigeration unit in the horizontal plane at a height of 3m and at 1 measuring point above the transport refrigeration unit (see figure 10.1).

The distance from the 2 measuring points in the horizontal plane to the geometric center of the refrigeration unit is 7.5m. By way of exception, measurements may be taken at 2m above the refrigeration unit instead of 7.5m, converting the level to 7.5m as follows:

$L_{pA, \max, 7.5m \text{ calculated}} = L_{pA, \max, 2m \text{ measured}} - 11 \text{ dB(A)}$, to a noise level at 7.5m. If measurements can be taken at 7.5m above the vehicle, this will be preferable.

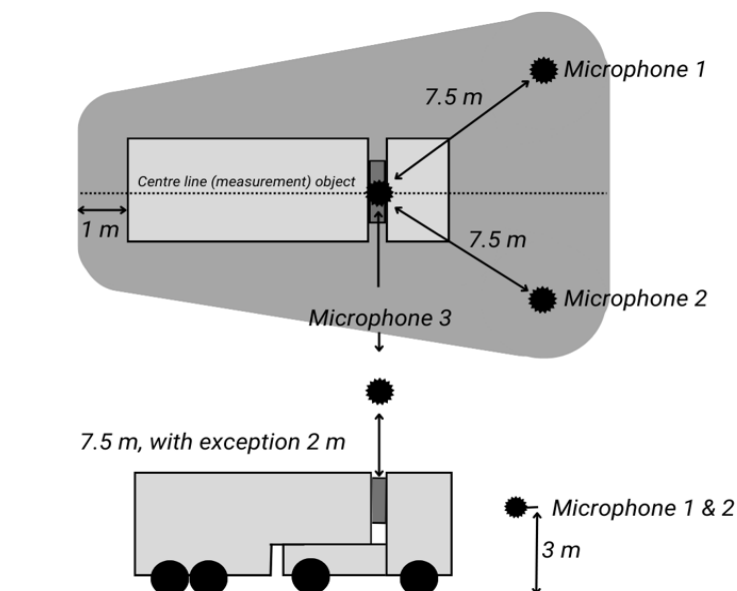

Figure 10.1 Measuring points around the transport refrigeration unit mounted to the front end

10.2.2 Measuring points for refrigeration unit underneath cargo body

If the refrigeration unit is not mounted to the front end, but underneath the cargo body, the measuring points indicated in figure 10.2 will be used rather than the measuring points indicated in figure 10.1.



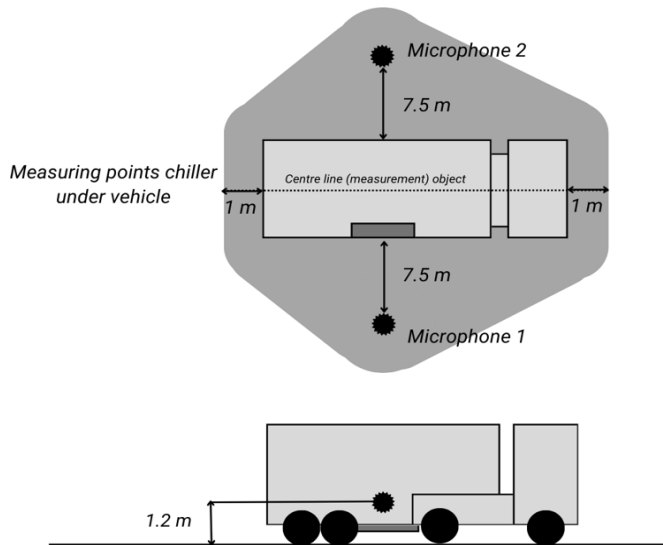

Figure 10.2 Measuring points if the refrigeration unit is mounted underneath the vehicle.

10.2.3 Additional measuring point for unit powered by trucks engine

If the trucks engine is used to power the refrigeration unit, a measuring point at 7.5m from the front of the engine compartment and at a height of 1.2m in accordance with figure 10.3 will be chosen in addition to the measuring points indicated in figure 10.1 or 10.2. The entire installation shall be operational during the measurements.

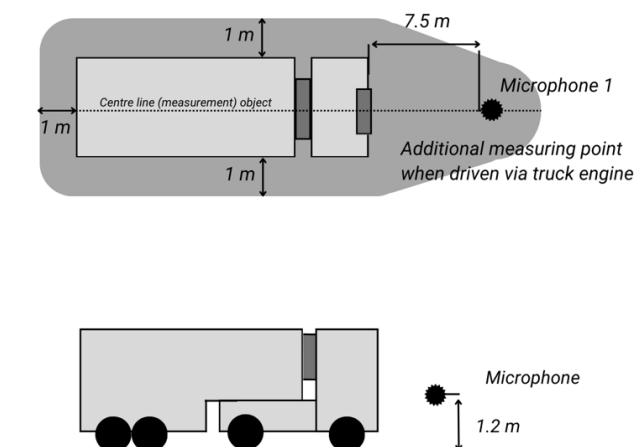

Figure 10.3: Additional measuring point for unit powered by the engine of the vehicle

10.2.4 Additional measuring points for driving system underneath cargo body

If the drive system for the refrigeration unit is mounted underneath the vehicle (10.3.4 and 10.3.5), measuring points will be selected at 7.5m from the sides of the vehicle, positioned parallel to the center of the drive unit (e.g. diesel engine, compressor, hydraulic motor, etc.) at a height of 1.2m in accordance with figure 10.4, in addition to the measuring points indicated in figure 10.1 or 10.2. The entire installation shall be operational during the measurements.



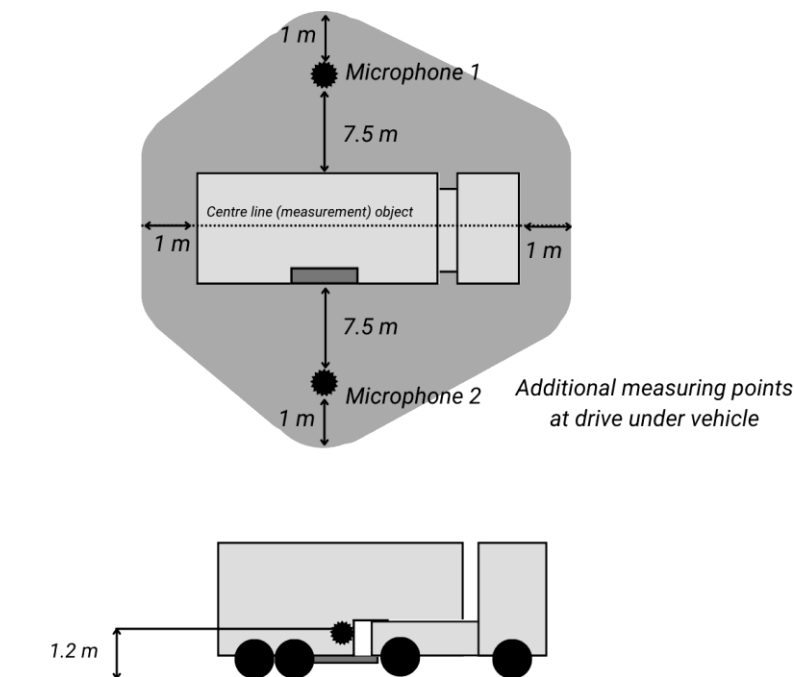

Figure 10.4 Additional measuring points for drive system underneath cargo body

10.3 Measurement procedures

There are different measurement procedures for the refrigeration systems described in 10.1. These measurement procedures are described in 10.3.

It may be possible to drive a refrigeration system in various ways, for example, using an integrated combustion engine and through a power connection with the public mains. If a refrigeration system can be driven in various ways, all possible methods shall be tested.

Only a full system can be evaluated; individual parts such as a (quickly exchangeable) powerpack cannot be evaluated separately.

10.3.1 Evaluation of refrigeration system with integrated combustion engine (see 10.1.1 Refrigeration system with integrated combustion engine)

The following measurement procedure shall be completed:

- Position the vehicle in a measuring location, switch off the engine of the truck.
- To guarantee that the refrigeration system to be measured operates under full load, the noise measurement will have to be taken at a cargo body temperature of between +15°C and +5°C, with the 'set' temperature at -/- 20°C. If the refrigeration system cannot be set to a 'set' temperature of -/- 20°C, the refrigeration system shall be set to the lowest possible 'set' temperature



- Start the diesel engine of the refrigeration unit, turn the refrigeration unit on and set it to the 'diesel-high' operating condition or to PEAK mode (unit settings in accordance with the manufacturer's instructions)
- Main evaporator/evaporator with greatest capacity is operational
- Read the maximum noise levels every 10 seconds for about 30 seconds (at least 3 readings)
- The measurement result is the highest value read from the measuring points and any value corrected to a distance of 7.5m, rounded to the nearest integer number in accordance with paragraph 3.3

For the 'diesel-low' operating conditions, the noise level is lower than for the 'diesel-high' operating conditions. As the diesel engine runs at reduced RPM in the 'low' setting, this situation will therefore not be evaluated.

If the compressor can be powered by an additional electric motor (connection to the public mains), the refrigeration system will also be measured in accordance with 10.3.6.

10.3.2 Evaluation of refrigeration system without separate combustion engine (see 10.1.2.1 Refrigeration system without separate combustion engine)

The following measurement procedure shall be completed:

- Position vehicle in measuring location, leave truck engine running.
- To guarantee that the refrigeration system to be measured operates under full load, the noise measurement will have to be taken at a cargo body temperature of between +15°C and +5°C, with the 'set' temperature at -/- 20°C. If the refrigeration system cannot be set to a 'set' temperature of -/- 20°C, the refrigeration system shall be set to the lowest possible 'set' temperature.
- Turn on the refrigeration unit and set it to the 'fast' or 'high' operating condition or to PEAK mode (unit settings in accordance with the manufacturer's instructions).
- Main evaporator/evaporator with greatest capacity is operational.
- Read the maximum noise levels every 10 seconds for about 30 seconds (at least 3 readings).
- The measurement result is the highest value read from the measuring points and any value corrected to 7.5m, rounded to the nearest integer number in accordance with paragraph 3.3.

At the current state of the art, the noise level of the truck combustion engine will be higher than the noise level produced by the refrigeration system when performing the above measurement procedure. Until vehicles are introduced that can be used to perform the above test, the refrigeration unit may be measured using a connection to the public mains in accordance with measurement procedure 10.3.6. If the system has an "overnight cooling system" using a power connection and an electric drive system, this system shall also be tested as stated under 10.3.6.



10.3.3 Evaluation of refrigeration system without separate combustion engine (see 10.1.2.2 Refrigeration system without separate combustion engine, with a compressor directly connected to the vehicle's engine)

The following measurement procedure shall be completed:

- Position vehicle in measuring location, leave vehicle engine running and bring it to its operating temperature.
- To guarantee that the refrigeration system to be measured operates under full load, the noise measurement will have to be taken at a cargo body temperature of between +15°C and +5°C, with the 'set' temperature at -/- 20°C. If the refrigeration system cannot be set to a 'set' temperature of -/- 20°C, the refrigeration system shall be set to the lowest possible 'set' temperature.
- Turn on the refrigeration unit and set it to the 'fast' or 'high' operating condition or to PEAK mode (unit settings in accordance with manufacturer's instructions).
- Main evaporator/evaporator with greatest capacity is operational.
- Read the maximum noise levels every 10 seconds for about 30 seconds (at least 3 readings).
- The measurement result is the highest value read from the measuring points and any value corrected to 7.5m, rounded to the nearest integer number in accordance with paragraph 3.3.

At the current state of the art, the noise level of the truck combustion engine will be higher than the noise level produced by the refrigeration system when performing the above measurement procedure. Until vehicles are introduced that can be used to perform the above test, the refrigeration unit may be measured using a connection to the public mains in accordance with the measurement procedure below.

If the system has an "overnight cooling system" using a power connection and an electric drive system, this system shall also be tested *as stated under 10.3.6*

10.3.4 Evaluation of refrigeration system without separate combustion engine (see 10.1.2.3 Refrigeration system without separate combustion engine, with additional support by a (quickly exchangeable) powerpack)

The following measurement procedure shall be completed if the system can operate without a functioning powerpack ((diesel) generator set):

- Position vehicle in measuring location, switch off engine of the vehicle.
- Electrically connect the refrigeration system to the public mains.
- To guarantee that the refrigeration system to be measured operates under full load, the noise measurement will have to be taken at a cargo body temperature of between +15°C and +5°C, with the 'set' temperature at -/- 20°C. If the refrigeration system cannot be set to a 'set' temperature of -/- 20°C, the refrigeration system shall be set to the lowest possible 'set' temperature.
- Turn on the refrigeration unit and set it to the 'fast' or 'high' operating condition or to PEAK mode (unit settings in accordance with the manufacturer's instructions).
- Main evaporator/evaporator with greatest capacity is operational.
- Read the maximum noise levels every 10 seconds for about 30 seconds (at least 3 readings).
- The measurement result is the highest value read from the measuring points and



any value corrected to 7.5m, rounded to the nearest integer number in accordance with paragraph 3.3.

The following measurement procedure shall also be followed if the system has a functioning powerpack ((diesel) generator set):

- Position vehicle in measuring location, switch off engine of the vehicle.
- Start powerpack and set it to the 'fast' or 'high' operating conditions (unit settings in accordance with manufacturer's instructions). Run the engine until it reaches its operating temperature.
- To guarantee that the refrigeration system to be measured operates under full load, the noise measurement will have to be taken at a cargo body temperature of between +15°C and +5°C, with the 'set' temperature at -/- 20°C. If the refrigeration system cannot be set to a 'set' temperature of -/- 20°C, the refrigeration system shall be set to the lowest possible 'set' temperature.
- Turn on the refrigeration unit and set it to the 'fast' or 'high' operating condition or to PEAK mode (unit settings in accordance with manufacturer's instructions).
- Main evaporator/evaporator with greatest capacity is operational.
- Read the maximum noise levels every 10 seconds for about 30 seconds (at least 3 readings).
- The measurement result is the highest value read from the measuring points and any value corrected to 7.5m, rounded to the nearest integer number in accordance with paragraph 3.3.

For the 'slow' or 'low' operating conditions, the noise level is lower than for the 'diesel-high' operating conditions. As the diesel engine runs at reduced RPM in the 'low' setting, this situation will therefore not be evaluated.

10.3.5 Evaluation of refrigeration system with external combustion engine (see 10.1.2.4 Systems with the original integrated diesel engine installed externally)

The following measurement procedure shall be completed:

- Position vehicle in measuring location, switch off the engine of the vehicle.
- Start diesel engine of refrigeration unit and leave it running until it reaches its operating temperature. Turn on the refrigeration unit and set it to the 'fast' or 'high' operating condition or to PEAK mode (unit settings in accordance with the manufacturer's instructions).
- To guarantee that the refrigeration system to be measured operates under full load, the noise measurement will have to be taken at a cargo body temperature of between +15°C and +5°C, with the 'set' temperature at -/- 20°C. If the refrigeration system cannot be set to a 'set' temperature of -/- 20°C, the refrigeration system shall be set to the lowest possible 'set' temperature.
- Main evaporator/evaporator with greatest capacity is operational.
- Read the maximum noise levels every 10 seconds for about 30 seconds (at least 3 readings).
- Read the maximum noise levels per measuring point during the entire cycle.



The measurement result is the highest value of the measuring points and any value corrected to 7.5m, rounded to the nearest integer number in accordance with paragraph 3.3.

If the compressor can be powered by an additional electric motor (connection to the public mains), the refrigeration system will also be measured in accordance with 10.3.6.

10.3.6 Evaluation of electrically powered refrigeration system with a connection to the public mains and refrigeration system based on an “open” gas system with a connection to the public mains

The following measurement procedure shall be completed:

- Position vehicle in measuring location, switch off vehicle engine or other combustion engine.
- Electrically connect the refrigeration system to the public mains.
- To guarantee that the refrigeration system to be certified operates under full load, the noise measurement will have to be taken at a cargo body temperature of between +15°C and +5°C, with the ‘set’ temperature at -/- 20°C. If the refrigeration system cannot be set to a ‘set’ temperature of -/- 20°C, the refrigeration system shall be set to the lowest possible ‘set’ temperature.
- Turn on the refrigeration unit and set it to the ‘fast’ or ‘high’ operating condition or to PEAK mode (unit settings in accordance with manufacturer's instructions).
- Main evaporator/evaporator with greatest capacity is operational.
- Read the maximum noise levels every 10 seconds for about 30 seconds (at least 3 readings).
- The measurement result is the highest value read from the measuring points and any value corrected to 7.5m, rounded to the nearest integer number in accordance with paragraph 3.3.

10.3.7 Evaluation of electrically powered refrigeration system with a connection to the vehicle's battery and refrigeration system based on an “open” gas system with a connection to the vehicle's battery

The following measurement procedure shall be completed:

- Position vehicle in measuring location, switch off engine of the vehicle.
- To guarantee that the refrigeration system to be measured operates under full load, the noise measurement will have to be taken at a cargo body temperature of between +15°C and +5°C, with the ‘set’ temperature at -/- 20°C. If the refrigeration system cannot be set to a ‘set’ temperature of -/- 20°C, the refrigeration system shall be set to the lowest possible ‘set’ temperature
- Turn on the refrigeration system and set it to the ‘fast’ or ‘high’ operating condition or to PEAK mode (unit settings in accordance with manufacturer's instructions).
- Main evaporator/evaporator with greatest capacity is operational.
- Read the maximum noise levels every 10 seconds for about 30 seconds (at least 3 readings)
- The measurement result is the highest value read from the measuring points and any value corrected to 7.5m, rounded to the nearest integer number in accordance with paragraph 3.3.



If the compressor can be powered by an additional electric motor (connection to the public mains), the refrigeration system will also be measured in accordance with 10.3.6.

10.4 Refrigeration system with “PEAK mode”

For a refrigeration unit that is fitted with a driver-independent “PEAK mode” control system, it shall be demonstrated that “PEAK mode” functions in addition to the above methods of measurement.

“PEAK mode” shall ensure that the refrigeration unit meets the legal noise requirements within 300 meters from the loading/unloading location.

There are several types of driver-independent “PEAK modes”.

The basic principle of a “PEAK mode” is that it is driver-independent and that, outside of the PEAK-specified time frames and outside of the so-called peak locations, the machine can be set to maximum power with technical tools. In other words, “PEAK mode” is the normal operating setting of the machine.

In case of a defect in the technical tool or other faults relating to the functioning of PEAK mode, the machine should operate in “PEAK mode”.

The functioning of “PEAK mode” shall be guaranteed. The functioning of “PEAK mode” shall also be demonstrated and described in the report.



11. Reporting

The test report shall be prepared by an independent expert who performed the noise measurement or under whose auspices the noise measurement was carried out.

The test report shall contain all relevant information (in wording and pictures) about the measurement(s) carried out and the measured product(s). Test reports shall be in English or French language. Test reports that meet the requirements can be assessed by Cemafruid. After a positive assessment, the type-approval certificate is issued.

In case of a product family, the description of the product family and the justification of the tested product in combination with the product family shall be handed over to Cemafruid. For QuietTRUCK the independent expert gives and advises about vehicle family definition and the representative vehicle.

11.1 General information

At least the following information about the measurements that shall be included in the measurement report:

Company name of the independent expert.

Name the operator/supervisor of the sound measurement. Create the name of the report.

Method of measurement

Name of the measurement protocol that is used.

Paragraph title and number of the Measurement methods for PEAK noise during loading and unloading (2024 update) and description of the preformed test method: (where applicable, indicate any deviations from the method and the reason for doing so). In case a measurement is exempted based on other certifications (R51-03, R138 or R165 as described in 2.2.1), the relevant information from those certifications is to be included in the report.

For the reverse alarm signal measurement, the specify method used to determine the height at which the highest sound pressure level is being measured. Either through scanning or measuring at fixed interval, in the latter case please specify the height interval in meters.

Measuring environment

Description of the measuring location:

- Date and time of measurements.
- Description of the weather conditions: including temperature, wind speed, rainfall.
- Distance to reflecting objects (walls, etc.).
- Distance to a not 'acoustically' hard surface.
- Surface dimensions in relation to measurement of object and microphone(s).
- If indoors, dimensions and furnishings of the space.
- Description of the testing location and surroundings.



- Description of the surface of the testing location included detail picture(s) of the surface.
- Background level ($L_{pA, \max, \text{Fast}}$) in dB(A).
- Pictures of the measured object with immediate surroundings, from all sides of the measured object, figure 11.1.

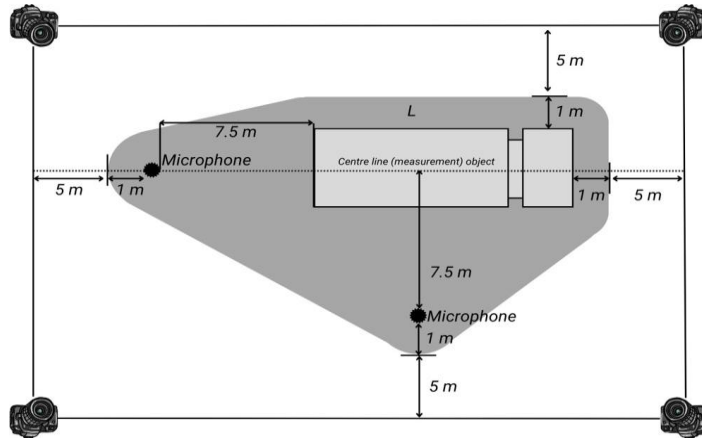

Figure 11.1 Required pictures of the measurement setup and location

Measuring equipment

List of measuring equipment, used, indicating the type, type number, serial number, and last calibration date.

Measuring quantity: $L_{pA, \max}$

Description of other equipment used during the measurement. In case of using a 'quiet' roll container, also a description and picture(s) of the container with load included in the wheels.

Load and operating condition

If laden, describe the load. Operation method.

Pictures of the load.

Speed of operation and / or driving.

Measuring points

Distance to the source and height of the measuring microphone for each measuring point.

Pictures of the measuring points in relation to the measured object and in relation to the immediate surroundings.

Measured levels and processing

All the levels read for each measuring condition and each measuring point. Any intermediate results. Number of averaging operations and type of averaging.

Measurement results by type of source and measuring condition

The measurement result is in the report for each type of source and measuring condition.



11.2 Product details

The test report shall describe the product on which the measurement has been carried out to become. This description shall be supported with photos, etc.

For the description, the form belonging to the product shall be included in the test report. The forms contain generic product data; specific product data shall be added.

11.2.1 Vehicle doors, hatches, hinged and roller doors

Description of vehicle doors, hatches, hinged and roller doors:

Manufacturer	
Make	
Type	
Hinge	
Make	
Type	
Number	
Picture	Place picture here
Locking system	
Make	
Type	
Number	
Picture	Place picture here
Door grip	
Make	
Type	
Number	
Picture	Place picture here
Door catch	
Make	
Type	
Number	
Picture	Place picture here
Rubber	
Make	
Type	
Number	
Picture	Place picture here
Other	
Part name	
Make	
Type	
Number	
Picture	Place picture here
PEAK-specific modification	
Part name	



Make	
Type	
Number	
Picture	Place picture here

11.2.2 Air curtain

Description of air curtain:

Manufacturer	
Make	
Type	
Fan	
Make	
Type	
Number	
RPM	
Picture	Place picture here
Enclosure	
Material	
Material thickness	
Picture	
Insulation material	
Insulation material	
Insulation material thickness	
Picture	Place picture here
Other	
Part name	
Make	
Type	
Number	
Picture	Place picture here
PEAK-specific modification	
Part name	
Make	
Type	
Number	
Picture	Place picture here



11.2.3 Roller door

Description of roller door:

Manufacturer	
Make	
Type	
Wheels	
Make	
Type	

Number	
Picture	Place picture here
Wheel bearing	
Make	
Type	
Number	
Picture	Place picture here
Locking system	
Make	
Type	
Number	
Picture	Place picture here
Rubber	
Make	
Type	
Number	
Picture	Place picture here
Stop	
Type	
Material	
Picture	Place picture here
If electric	
Electric motor	
Make	
Type	
RPM	
Picture	Place picture here
If pneumatic	
Cylinder	
Make	
Type	
Picture	Place picture here
Opening speed	
Other	
Part name	
Make	
Type	
Number	



Picture	Place picture here
PEAK-specific modification	
Part name	
Make	
Type	
Number	
Picture	Place picture here

11.2.4 Sliding panel

151

Description of sliding panel:

Manufacturer	
Make	
Type	
Wheels	
Make	
Type	
Number	
Picture	Place picture here
Wheel bearing	
Make	
Type	
Number	
Picture	Place picture here
Locking system	
Make	
Type	
Number	
Picture	Place picture here
Stop	
Type	
Material	
Picture	Place picture here
Other	
Part name	
Make	
Type	
Number	
Picture	Place picture here
PEAK-specific modification	
Part name	
Make	
Type	
Number	
Picture	Place picture here



11.2.5 Sliding partition

Description of sliding partition

Manufacturer	
Make	
Type	
Wheels	
Make	
Type	
Number	
Picture	Place picture here

Wheel bearing	
Make	
Type	
Number	
Picture	Place picture here
Locking system	
Make	
Type	
Number	
Picture	Place picture here
Locking system	
Make	
Type	
Number	
Picture	Place picture here
Rubber	
Make	
Type	
Picture	Place picture here
Stop	
Type	
Material	
Picture	Place picture here
Rails	
Make	
Type	
Picture	Place picture here
Other	
Part name	
Make	
Type	
Number	
Picture	Place picture here
PEAK-specific modification	
Part name	
Make	



Type	
Number	
Picture	Place picture here

11.26 Steps

Description of steps

Manufacturer	
Make	
Type	
Material	
Type	

Thickness	
Picture	Place picture here
Rubber	
Make	
Type	
Picture	Place picture here
Stop	
Type	
Material	
Picture	Place picture here
Other	
Part name	
Make	
Type	
Number	
Picture	Place picture here
PEAK-specific modification	
Part name	
Make	
Type	
Number	
Picture	Place picture here

11.27 Strip curtain

Description of curtain

Manufacturer	
Make	
Type	
Wheels	
Make	
Type	
Number	
Picture	Place picture here
Wheel bearing	
Make	



Type	
Number	
Picture	Place picture here
Stop	
Type	
Material	
Picture	Place picture here
Strips	
Number	
Material	
Thickness	
Picture	Place picture here

Other	
Part name	
Make	
Type	
Number	
Picture	Place picture here
PEAK-specific modification	
Part name	
Make	
Type	
Number	
Picture	Place picture here

11.2.8 Tail lift

Description of tail lift

Manufacturer	
Make	
Type	
Version	rear-closing tail lift / slides underneath vehicle / internal vertical tail lift
Engine	
Make	
Type	
RPM	
Picture	Place picture here
Pump	
Make	
Type	
RPM	
Picture	Place picture here
Roll-off stop type	
Roll-off stop modifications	
Picture	Place picture here
Rollers	



Make	
Type	
Number	
Picture	Place picture here
Rubber possibly present on rear frame	
Make	
Type	
Thickness	
Number	
Picture	Place picture here

Rubber possibly present at bottom of cargo body	
Make	
Type	
Thickness	
Number	
Picture	Place picture here
Platform	
Material structure	
If coating present	
Make	
Type	
Thickness	
Coating material	
Coating thickness	
Picture	Place picture here
Other	
Part name	
Make	
Type	
Number	
Picture	Place picture here
PEAK-specific modification	
Part name	
Make	
Type	
Number	
Picture	Place picture here

11.29 Floor

Description of floor:

Manufacturer	
--------------	--



Make	
Type	
Floor	
Make	
Type	
Structure	
Thickness	
Attachment top layer	
Surface structure	
Picture	Place picture here
If coating present	
Make	
Type	

Thickness	
Surface structure	
Picture	Place picture here
Anti-skid	
Picture	Place picture here
Other	
Part name	
Make	
Type	
Number	
Picture	Place picture here
PEAK-specific modification	
Part name	
Make	
Type	
Number	
Picture	Place picture here

11.2.10 Wall

Description of wall:

Manufacturer	
Make	
Type	
Wall	
Make	
Type	
Material	
Structure	
Thickness	
Picture	Place picture here
If impact plate present	
Make	



Type	
Dimensions	
Attachment method	
Picture	Place picture here
Other	
Part name	
Make	
Type	
Number	
Picture	Place picture here
PEAK-specific modification	
Part name	
Make	
Type	
Number	
Picture	Place picture here



11.2.11 Load fastening system

Description of load fastening system

Locking system	
Manufacturer	
Make	
Type	
Locking system type	
Material	
Picture	Place picture here
Rail	
Manufacturer	
Make	
Type	
Material	
Attachment method	
Picture	Place picture here
Other	
Part name	
Make	
Type	
Number	
Picture	Place picture here
PEAK-specific modification	
Part name	
Make	
Type	
Number	
Picture	Place picture here

11.2.12 Refrigeration unit

Description of refrigeration unit:

Manufacturer	
Make	
Model	
Type	
Where applicable: Variation on standard type:	
PEAK mode: Operating method	
Drive system type:	Powered by vehicle engine / Powered by separate diesel engine Electrically powered / Diesel-electrically powered Nitrogen unit / Carbon dioxide unit

Diesel engine	
Make	

Type	
RPM	
Picture	
Compressor	
Make	
Type	
RPM	
Picture	Place picture here
Generator frequency (where applicable)	
RPM of condenser fan(s)	
Noise insulation method:	
Enclosure material	
Material thickness	
Picture	
Where applicable for separate drive system	
Enclosure material	
Material thickness	
Picture	
Insulation	
Insulation material	
Insulation material thickness	
Insulation material type	
Picture	Place picture here
Damping fitted inside enclosure	yes/no
Where applicable: water- or air-cooled generator	
Exhaust damper	
Make	
Type	
Dimensions of exhaust damper	
Location of exhaust damper	
Release location of exhaust gases	
Picture	Place picture here
Method of mouting to vehicle	
	Place picture here

Other	
Part name	

Make	
Type	
Number	
Picture	Place picture here
PEAK-specific modification	
Part name	
Make	
Type	
Number	
Picture	Place picture here
Evaporator (operating during testing)	
Make	
Type	
Capacity	

11.2.13 QuietTruck

Description of the truck

0. General
0.1. Make (trade name of manufacturer):
0.2. Means of identification of type, if marked on the vehicle: ¹
0.2.1. Location of that marking:
0.3. Category of vehicle: ²
0.4. Company name and address of manufacturer:
0.5. Name and address of the manufacturer's representative (if any):
0.6. Name(s) and address(es) of assembly plant(s):
0.7 Building series (model year):
1. General construction characteristics of the vehicle
1.1. Photographs and/or drawings of a representative vehicle:
1.2. Number of axles and wheels: ³
1.2.1. Powered axles (number, position, interconnection):
1.3. Position and arrangement of the engine:
2. Masses and dimensions ⁴ (in kg and mm) (Refer to drawing where applicable):
2.1. Range of vehicle dimensions (overall):
2.1.1. For chassis without bodywork:
2.1.1.1. Length:
2.1.1.2. Width:
2.1.2. For chassis with bodywork
2.1.2.1. Length:
2.1.2.2. Width:
2.1.3. Wheelbase:



2.2. Mass in running order ⁵
(a) Minimum and maximum for each variant:
(b) Mass of each version (a matrix shall be provided):
2.3. Technically permissible maximum laden mass stated by the manufacturer: ^{6,7}
3. Power plant ⁸
3.1. Manufacturer of the engine:
3.1.1. Manufacturer's engine code (as marked on the engine, or other means of identification):
3.2. Internal combustion engine
3.2.1. Specific engine information
3.2.1.1. Working principle: positive ignition/compression ignition, cycle four stroke/two stroke/rotary ⁹
3.2.1.2. Number and arrangement of cylinders:
3.2.1.2.1. Firing order:
3.2.1.3. Engine capacity: ¹⁰ cm ³
3.2.1.4. Rated maximum net power: kW at min ⁻¹ (manufacturer's declared value)
3.2.2. Fuel feed
3.2.2.1. By fuel injection (compression ignition only): yes/no ⁹
3.2.2.1.1. Working principle: Direct injection/pre-chamber/swirl chamber ⁹
3.2.2.1.2. Governor
3.2.2.1.2.1. Type:
3.2.2.1.2.2. Speed at which Cut-off starts under load: min ⁻¹
3.2.2.2. By fuel injection (positive ignition only): yes/no ⁹
3.2.2.2.1. Working principle: Intake manifold (single-/multi-point ²)/direct injection/other (specify)
3.2.3. Intake system
3.2.3.1. Air filter, drawings, or
3.2.3.1.1. Make(s):
3.2.3.1.2. Type(s):
3.2.3.2. Intake silencer, drawings,
3.2.3.2.1. Make(s):
3.2.3.2.2. Type(s):
3.2.4. Exhaust system
3.2.4.1. Description and/or drawing of the exhaust system:
3.2.4.2. Exhaust silencer(s):
Type, marking of exhaust silencer(s):
Where relevant for exterior noise, reducing measures in the engine compartment and on the engine:
3.2.4.3. Location of the exhaust outlet:

3.2.4.4. Exhaust silencer containing fibrous materials:
3.2.5. Catalytic convertor: yes/no ⁹
3.2.5.1. Number of catalytic convertors and elements (provide the information below for each separate unit):
3.3. Electric motor
3.3.1. Type (winding, excitation):
3.3.1.1. Maximum hourly output kW
3.3.1.2. Operating voltage V
3.4. Engine or motor combination:
3.4.1. Hybrid electric vehicle: yes/no ⁹
3.4.2. Category of hybrid electric vehicle: off-vehicle charging/not off-vehicle charging: ⁹
3.4.3. Operating mode switch: with/without ⁹
3.4.3.1. Selectable modes
3.4.3.1.1. Pure electric: yes/no ⁹
3.4.3.1.2. Pure fuel consuming: yes/no ⁹
3.4.3.1.3. Hybrid modes: yes/no ⁹ (if yes, short description):
3.4.4. Electric motor (describe each type of electric motor separately)
3.4.4.1. Make:
3.4.4.2. Type:
3.4.4.3. Rated maximum net power kW
3.4.5. PEAK-mode
3.4.5.1. Make:
3.4.5.2. Operation method:
3.4.6 AVAS
3.4.6.1 Sound level according to UN/ECE Regulation No 138 reverse test:
4. Transmission ¹¹
4.1. Type (mechanical, hydraulic, electric, etc.):
4.2. Gear ratios

<i>Gear</i>	<i>Internal gearbox ratios (ratios of engine to gearbox output shaft revolutions)</i>	<i>Final drive ratio(s) (ratio of gearbox output shaft to driven wheel revolutions)</i>	<i>Total gear ratios</i>
Maximum for CVT ¹²			
1			
2			
3			
...			
Minimum for CVT			
Reverse			

4.2.1 Where relevant for exterior noise, reducing measures in the transmission compartment and on the transmission:

4.3. Maximum vehicle design speed (in km/h):¹³

5. Suspension

5.1. Tyres and wheels

5.1.1. Tyre/wheel combination(s)

(a) For tyres indicate size designation, load-capacity index and speed

category symbol;

(b) For wheels, indicate rim size(s) and off-set(s).

5.1.2. Upper and lower limits of rolling radii

5.1.2.1. Axle 1:

5.1.2.2. Axle 2:

5.1.2.3. Axle 3:

5.1.2.4. Axle 4:

etc.

6. Axle

6.1.1. Axle ratio 1:

5.1.2. Axle ratio 2:

5.1.3. Axle ratio 3:

5.1.4. Axle ratio 4:

7. Bodywork

7.1. Type of bodywork:

7.2. Materials used and methods of construction:

7.3. Lateral protection (side guards) :

7.3.1. Material(s) :

7.3.2. Dimensions:

7.4. Mudguards:

7.4.1. Make:

7.4.2. Type:

7.5 Type of cabin
7.5.1. Where relevant for exterior noise, reducing measures in/at the cabin
8. Miscellaneous
8.1. Details of any non-engine devices designed to reduce noise (if not covered by other items):
1 If the means of identification of type contains characters not relevant to describe the vehicle types covered by the type-approval certificate such characters shall be represented in the documentation by the symbol: '?' (e.g. ABC??123??).
2 As defined in the Consolidated Resolution on the Construction of Vehicles (R.E.3.), document ECE/TRANS/WP.29/78/Rev.3, para. 2 - www.unece.org/trans/main/wp29/wp29wgs/wp29gen/wp29resolutions.html
3 Only for the purpose of defining "off-road vehicles".
4 Standard ISO 612: 1978 — Road vehicles — Dimensions of motor vehicles and towed vehicles - terms and definitions. (a) Where there is one version with a normal cab and another with a sleeper cab, both sets of masses and dimensions are to be stated. (b) Optional equipment that affects the dimensions of the vehicle shall be specified.
5 The mass of the driver is assessed at 75 kg. The liquid containing systems (except those for used water that shall remain empty) are filled to 90 per cent of the capacity specified by the manufacturer. The information referred to in points 2.2. (b) do not need to be provided for vehicle categories N2, N3, M2 and M3.
6 For vehicles coupled with a trailer or a semi-trailer, which exert a significant vertical load on the coupling device or the fifth wheel, this load, divided by standard acceleration of gravity, is included in the maximum technically permissible mass. Please fill in here the upper and lower values for each variant.
7 Please fill in here the upper and lower values for each variant.
8 In the case of a vehicle that can run either on petrol, diesel, etc., or also in combination with another fuel, items shall be repeated. In the case of non-conventional engines and systems, particulars equivalent to those referred here shall be supplied by the manufacturer.
9 Delete what does not apply.
10 This value shall be calculated ($\pi = 3.1416$) and rounded off to the nearest cm^3 .
11 The specified particulars are to be given for any proposed variants.
12 Continuous Variable Transmission (CVT): transmission with variable gear ratios.
13 With respect to trailers, maximum speed permitted by the manufacturer.

11.2.14 Reversing alarm system and blind spot warning

Description of warning system

Make	
Type	
Picture	Place picture here
Other	
Part name	
Make	
Type	
Number	
Picture	Place picture here



Peak-specific modification	
Part name	
Make	
Type	
Number	
Picture	Place picture here

11.2.15 Rollies and dollies

Description of the rollie or dolly

Make	
Type	
Picture	Place picture here
Base	
Material	
Picture	Place picture here
Wheels	
Number	
Dimensions	
Material	
Hardness	
Picture	Place picture here
Castor	
Make	
Type	
Number	
Picture	Place picture here
Other	
Part name	
Make	
Type	
Number	
Picture	Place picture here
Peak-specific modification	
Part name	
Make	
Type	
Number	
Picture	Place picture here

11.2.16 Roll container

Description of the roll container

Make	
Type	
Picture	Place picture here
Base	



Material	
Picture	Place picture here
Frame	
Material	
Picture	Place picture here
Wheels	
Number	
Dimensions	
Material	
Hardness	
Picture	Place picture here
Castor	
Make	
Type	
Picture	Place picture here
Other	
Part name	
Make	
Type	
Number	
Picture	Place picture here
Peak-specific modification	
Part name	
Make	
Type	
Number	
Picture	Place picture here

11.2.17 Pallet truck

Description of pallettruck

Make	
Type	
Picture	Place picture here
Lifting capacity	
Lifting speed	
Driving speed	
Frame	
Material	
Picture	Place picture here
Wheels front	
Number	
Dimensions	
Material	
Hardness	
Picture	Place picture here
Wheels rear	



Number	
Dimensions	
Material	
Hardness	
Picture	Place picture here
Engine	
Make	
Type	
RPM	
Picture	Place picture here
Pump	
Make	
Type	
RPM	
Picture	Place picture here
Other	
Part name	
Make	
Type	
Number	
Picture	Place picture here

12. References

[1] 'Proposals for methods of measurement for peak noise during loading and unloading', TNO report HAG-RPT-980088, November 1998

[2] 'Feasibility study on reducing peak noise during loading and unloading', TNO report HAG-RPT-970095, 30 September 1997

[3] UN/ECE regulation R51 revision 3, "Uniform provisions concerning the approval of motor vehicles having at least four wheels with regard to their sound emissions", 5 February 2016, <http://www.unece.org/fileadmin/DAM/trans/main/wp29/wp29regs/updates/R051r3e.pdf>

[4] UNECE RE3; United Nations Economic Commission for Europe, Consolidated Resolution on the Construction of Vehicles (R.E. 3), Revision 1, Annex 7

[5] 'Method to determine the noise capacity level in dB(A) radiated by a forklift', Vamil publication series number 3.1, October 1997, Ministry of Housing, Spatial Planning and the Environment

[6] 'Feasibility study on quiet transport refrigeration', Environmental technology publication series, number 1990/3, Ministry of Housing, Spatial Planning and the



Environment

[7] 'Methods of measurement for peak noise during loading and unloading (2010 update)' TNO report MON-RPT-2010-00466, 18 February 2010

[8] 'Methods of measurement for peak noise during loading and unloading (2015 update)', Stichting Peak, 2015.

[9] 'Methods of measurement for peak noise during loading and unloading (2018 update)', Stichting Peak, 2018.

[10] UN/ECE Regulation No 85: Uniform provisions concerning the approval of internal combustion engines or electric drive trains intended for the propulsion of motor vehicles of categories M and N with regard to the measurement of net power and the maximum 30 minutes power of electric drive trains [R085r1e.pdf \(unece.org\)](#)

[11] UN/ECE Regulation No 138: Uniform provisions concerning the approval of Quiet Road Transport Vehicles with regard to their reduced audibility [2017/71] <https://unece.org/fileadmin/DAM/trans/main/wp29/wp29regs/2017/R138r1e.pdf>

[12] UN/ECE Regulation No 165: Uniform provisions concerning the approval of audible reverse warning devices and of motor vehicles with regard to their audible reverse warning signals [ECE/TRANS/WP.29/2021/49 \(unece.org\)](#)



1.

